

# ElectroMaax

OFF GRID ENERGY SOLUTIONS



## SOLARMAAX 340 LEVEL 1 WATERMAKER MANUAL



# TABLE OF CONTENTS

|   |           |
|---|-----------|
| INTRODUCTION.....   | 3         |
| GENERAL WARNINGS.....   | 4         |
| PARTS LIST.....   | 5         |
| SOLARMAAX 340 SPECIFICATIONS.....                                 | 6         |
| CONFIGURATIONS.....   | 8         |
| SYSTEM OVERVIEW.....  | 9         |
| INSTALLATION INSTRUCTIONS.....                                    | 10        |
| COMPONENTS IN ORDER OF WATER FLOW.....                            | 11        |
| INTAKE SEACOCK.....   | 11        |
| SEA STRAINER.....   | 11        |
| FRESHWATER FLUSH ASSEMBLY.....                                    | 12        |
| FEED PUMP ASSEMBLY.....   | 13        |
| MOUNTING THE FEED PUMP ASSEMBLY.....                              | 14        |
| FILTER STATUS GAUGE.....  | 15        |
| ACCUMULATOR TANK.....   | 15        |
| ENHANCED CLARK PUMP.....  | 16        |
| PRESSURE VESSEL & RO MEMBRANE ASSEMBLY.....                       | 17        |
| OPERATOR CONTROL PANEL.....                                       | 18        |
| 3-WAY SERVICE VALVE.....  | 19        |
| DISCHARGE THROUGH HAUL.....                                       | 19        |
| TANK FILL SELECTOR VALVE.....                                     | 20        |
| TDS TESTER AND TESTING PRODUCT WATER QUALITY.....                 | 20        |
| HANDHELD TDS TESTER MEASUREMENT INSTRUCTIONS.....                 | 21        |
| <i>PURE SILICONE GREASE PACKET.....</i>                           | <i>21</i> |
| MOUNTING THE COMPONENTS.....                                      | 22        |
| PLUMBING.....   | 23        |
| LOW PRESSURE TUBE AND FITTINGS.....                               | 24        |
| TUBING CONNECTION.....  | 25        |
| ELECTRICAL.....   | 26        |
| CONTROL SYSTEM.....   | 28        |
| COMMISSIONING.....  | 30        |
| NORMAL START UP.....  | 31        |
| NORMAL RUN.....   | 31        |
| SHUT-DOWN PROCEDURES.....   | 32        |
| <i>NORMAL SHUT-DOWN, NO FRESHWATER FLUSH.....</i>                 | <i>32</i> |
| <i>NORMAL SHUT-DOWN WITH A ONE TIME FLUSH.....</i>                | <i>32</i> |
| <i>NORMAL SHUT-DOWN WITH AUTO RE-FLUSH EVERY 3 TO 9 DAYS.....</i> | <i>33</i> |
| PICKLING FOR LONG-TERM STORAGE.....                               | 33        |
| <i>WINTERIZING.....</i>   | <i>34</i> |
| RESTARTING AFTER LONG-TERM STORAGE.....                           | 34        |
| PRE-FILTER SERVICE.....   | 35        |
| MEMBRANE CLEANING PROCEDURES.....                                 | 36        |
| MEMBRANE REPLACEMENT.....   | 37        |
| MODULE DIMENSIONS.....  | 42        |
| TROUBLESHOOTING.....  | 44        |

The team at Electromaax thanks you for your purchase of our SolarMaax 340 reverse osmosis watermaker with Auto Flush, and the latest in energy recovery technology; the Enhanced Clark Pump.

The addition of a low energy watermaker can be a life changing upgrade for your cruising experience. Used properly, you will never have to go out of your way just to get questionable and/or expensive water or lift jerry cans out of the dingy. The SolarMaax 340 can easily make enough for you and your crew to shower every day. In addition, it can pay for itself by being able to rinse salts off your boat and gear, reducing maintenance and replacement costs.

The SolarMaax 340 design is based on decades of real-world product testing and engineering from both marine and military applications. Ranging from supporting military operations in the mountains of Afghanistan to serious offshore yacht racing, as well as tranquil anchorages around the world.

We are confident that you will be completely satisfied with your new system and stand behind our product with an industry leading warranty and customer support.

# GENERAL WARNINGS

There are several things which the installer or operator of the SolarMaax 340 can do incorrectly, which can seriously damage the SolarMaax 340 water maker, dramatically shorten the operational life span of the system, and in some cases cause personal injury. Knowing the things to avoid is critical to a good SolarMaax 340 installation and operation. We will cover the following items again during the appropriate section later in the manual, however, due to their importance it is worth giving the following items extra attention.

**WARNING:** THE SOLAR MAAX IS DESIGNED TO BE USED IN TYPICAL SEA WATER. USING TASTE TO TEST THE QUALITY OF THE PRODUCT WATER ONLY WORKS WITH A SEA WATER FEED. OPERATING IN FRESHWATER WITHOUT STERILIZING THE PRODUCT COULD RESULT IN SICKNESS OR DEATH.

**WARNING:** WHEN DISASSEMBLING THE PRESSURE VESSEL, DO NOT TOUCH THE TREADS ON THE ENDS OF THE TUBE. THERE MAY BE FIBERGLASS SPLINTERS.

**NOTICE:** NEVER ALLOW CHLORINATED WATER TO COME IN CONTACT WITH THE RO MEMBRANES. OXIDANTS SUCH AS CHLORINE AND/OR BLEACH WATER WILL PERMANENTLY RUIN THE RO MEMBRANE.

**NOTICE:** NEVER RUN THE SolarMaax 340 IN OILY WATER. OIL WILL PERMANENTLY RUIN THE RO MEMBRANE.

**NOTICE:** DO NOT INSTALL THE RO MEMBRANE MODULE IN AN AREA WHERE THE RO MEMBRANES CAN BECOME HEAT SOAKED TO TEMPERATURES ABOVE 113°F/45

**NOTICE:** THE RO MEMBRANE MODULE IS SHIPPED IN A SEALED PACKAGE CONTAINING A STORAGE/PRESERVATIVE SOLUTION WHICH MUST BE PURGED AT SYSTEM START UP

**NOTICE:** GOOD ELECTRICAL SUPPLY TO THE FEED PUMP IS MANDATORY FOR PROPER SYSTEM OPERATION.

**NOTICE:** NEVER USE A 5 MICRON "CARBON" FILTER IN PLACE OF THE SUPPLIED 5 MICRON PREFILTER ELEMENT.

**NOTICE:** ONLY USE THE STORAGE CHEMICAL SUPPLIED BY ELECTROMAAX. OTHER BRANDS MY DAMAGE THE SYSTEM.

1. Clark Pump and Pressure Vessel Assembly
2. Membrane Elements
3. Feed Pump Assembly (Feed Pump, Prefilter, Pump Control Module)
4. Control Panel
5. Carbon Filter with Solenoid Valve for Automatic Freshwater Flush
6. Accumulator Tank with fittings (depressurized for shipping)
7. 3/4" Sea Strainer and Mount Bracket
8. Prefilter Status Gauge
9. 30' Coil 5/8" Tube, Black (Feed)
10. 10' Coil 5/8" tube, Clear (Flush)
11. 20' Coil 1/4" Tube, Black (Gauge)
12. 30' Coil 1/2" Tube, Red (Brine)
13. 30' Coil 1/4" Tube, Blue (Product)
14. 10" Coil Flush Valve 14/2 Power Cable

## SMALL PARTS LIST:

15. Handheld Salinity Sensor
16. Filter Wrench
17. Tubing Cutter
18. Tube Extractor Tool
19. Teflon Tape
20. Silicone Grease Packet
21. 8oz Container Memstor
22. 3/4" NPT to 3/4" Hose Barb – (Inlet Strainer)
23. 3/4" Check Valve – (Attached, Flush System)
24. 2X 5/8" Tube Tee – (Flush system, accum. tank)
25. 2X 1/2" 3 way Service Valves (Service Access)
26. 3X 3/4" NPT to 5/8" Tube Fitting (Strainer and Check Valve)
27. 3X 1/2" NPT to 5/8" Tube Fittings (Intake Service Valve)
28. 4X 1/2" NPT to 1/2" Tube Fittings (Brine Service Valve/Clark Pump)
29. 5/8" Tube Elbow Fitting (Clark Pump Stem Fitting)
30. 4X 1/4" Tube Fittings Elbow (Filter Gauge, Attached)
31. 18X 5/8" locking rings
32. 8X 1/2" locking rings
33. 8X 1/4" locking rings
34. 1/2" NPT to 5/8" Tube Stem (Check Valve attached)
35. 3/4" NPT to 1/2" NPT Bushing (Strainer, Attached)
36. 6X 5/8" Tube Elbow Fittings (Feed line)
37. 2X 1/2" Tube Elbow Fittings (Brine line)
38. 4X plastic U clamps (Service Valve Mounts)
39. 3/4" NPT short nipple (Check Valve, Strainer, Attached)
40. 3X 1/2" NPT Short Nipples (Service Valves)
41. 2X 1/8" NPT to 1/4" Tube Elbow Fittings

# SOLARMAAX 340 SPECIFICATIONS

**Production Rate:** 7-14 Gallons per hour, 26-53 liters per hour

The production rate is set by the displacement of the Enhanced Clark Pump energy recovery device and the feed flow rate. The SolarMaax 340 uses a 10% displacement Clark Pump so 10% of the feed water flow is turned into product water. Water temperature and salinity affect operating pressure but has little effect on production rate. Changes in feed flow does have an effect, the more feed flow the more product. Supplying good voltage to the feed pump gives the best production rate. Running the system while the batteries are bulk charging gives the highest production rate.

**RO Membrane:** The SolarMaax 340 Watermaker is equipped with Reverse Osmosis Membranes

*Membrane Type:* Polyamide Thin-Film Composite

*Membrane Model:* two SW2521

*Range of Operating Pressures:* 650 to 1000 psi (45 to 69 bar)

*Normal Operating Pressure:* Set by feed water conditions and feed flow rate.

*Salt Rejection rate:* 99.4%

*Maximum Operating Temperature:* 113°F (45°C)

*Minimum Storage/Operating Temp:* 32°F (0°C)

*Maximum Operating Pressure:* 1,000 psi, (69 bar)

*Maximum Pressure Drop:* 15 psi (1 bar)

*pH Range, Continuous Operation:* 2-11

*pH Range, short-term cleaning:* 1-12

*Free Chlorine Tolerance:* <0.1ppm

## **Electrical Power Requirements:**

8.0 – 20.0 amps @ 12.5-14.4 VDC

4.0 – 10.0 amps @ 25.0 – 28.8 VDC

## **The Enhanced Clark Pump Hydraulic Pressure Intensifier:**

Manufactured by ElectroMaax for marine and military use. The Enhanced Clark Pump uses the Feed pump flow pressure to intensify the pressure of the flow through the RO membranes high enough for reverse osmosis to occur. There are no electrical components.

*Displacement:* 10 %

*Feed Flow range:* 1.0 gpm (3.78 lpm) to 4.0 gpm (15.14 lpm)

*Maximum Inlet pressure:* up to 125 psi (8.6 bar)

*Maximum Working Pressure:* 1000 psi (68.9 bar)

*Maximum operating temperature:* 113°F (45°C)

*Maximum storage temperature:* 140°F (60°C)

*Pump Dimensions:* 26.38" (67cm) W, 5.75" (14.6cm) D, 8.0" (20.32cm) H

*Pressure Relief Valve:* Manually open ½ turn CCW for priming and servicing

### **Feed Pump:**

*Motor:* Permanent magnet type, fully enclosed, 1/8 hp

*Pump Body:* Thermoplastic

*Pump Type:* 3 chamber diaphragm

*Typical Amp Draw each:* 8 to 10 amps, 12VDC 4 to 5 amps 24VDC

*Recommended fuse size:* 25 amps, 12VDC 15 amps, 24VDC

*Flow Rate:* 1.6 gpm (6.05 lpm) open flow

### **Pressure Vessel:**

Filament wound fiberglass/epoxy compound with non-metallic wetted surfaces. Easily removable end caps for membrane replacement with larger than standard internal porting and fittings for increased energy efficiency. The most compact complete assembly available.

Max pressure - 1000 psi (69 Bar)

Burst pressure - 3000 psi (207 Bar)

### **Prefilter and Auto Freshwater Flush Filter housings:**

Industry standard, 10-inch, plastic, filter housings. Accepting 9.75" by 2.5" pleated filters and high flow carbon filter elements.

### **Clark Pump and Pressure Vessel Assembly, 2-21" Membranes:**

*Dimensions:* 16.3" (413 mm) W, 24.7" (630 mm) L, 8.4" (213 mm) H

*Weight:* 40.0 lbs. (18.2 kg)

### **Feed Pump Assembly:**

*Dimensions:* 14.1" (358 mm) W, 6.7" (170 mm) D, 13.6" (345 mm) H

*Weight:* 22.0 lbs. (9.9 kg)

### **Shipping:**

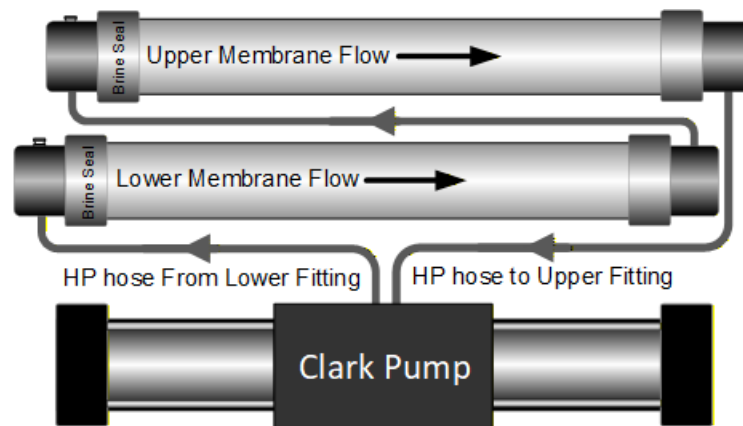
#### **3 Boxes**

30" x 12" x 12" -- 46lbs

18" x 18" x 16" – 30lbs

12" x 12" x 14" – 10lbs

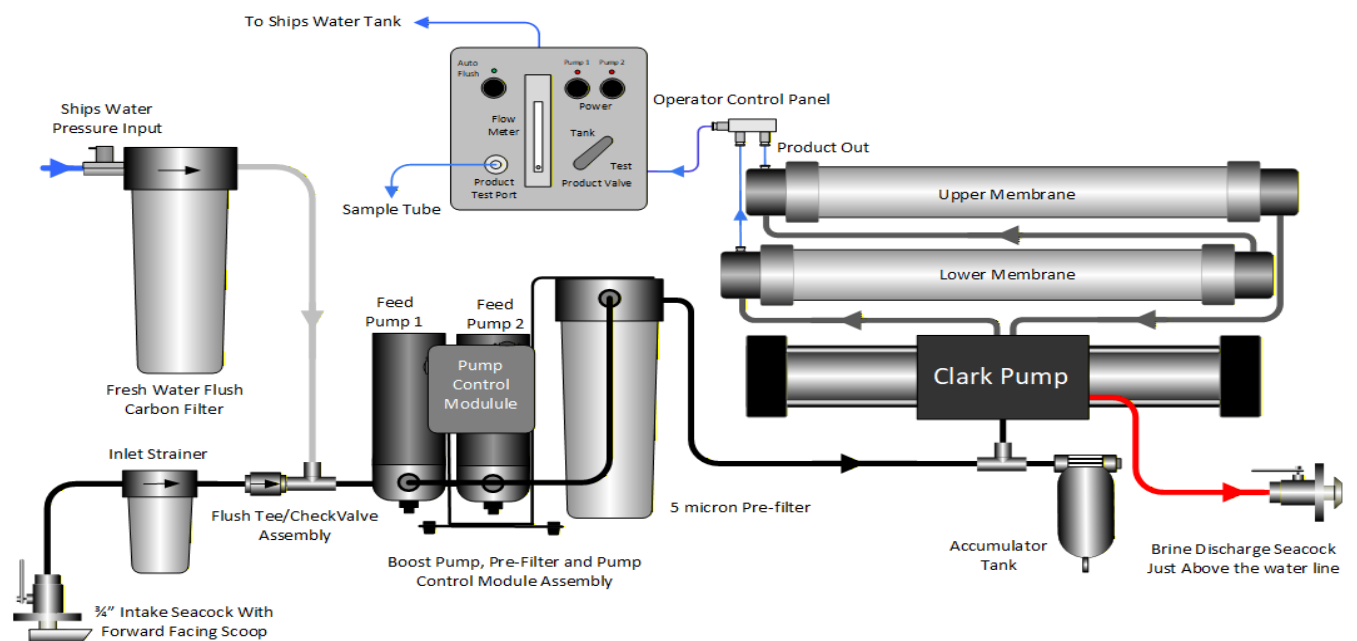
The *SolarMaax 340* consists of the Clark Pump and the Membranes mounted together on a base frame and plumbed together with High Pressure hoses. If a frame assembly cannot be reasonably mounted as a unit, the Clark Pump and Membrane can be separated for custom mounting. Usually, at least one new custom length HP hose will need to be ordered to complete the installation. Membrane flow must always be horizontal or uphill.



With double 21" membranes in series. One is mounted on top of the other to conserve space. Ideal for temperate to cold water operation and where a 40" membrane would be hard to fit. This will work in warm water with some increase in Product water TDS.

The *SolarMaax 340* is simple to install. When all the components are connected in the right order the system will perform as designed and give all the freshwater you need for years. Every installation is going to be different in where and how the components are mounted so forethought is necessary for the ideal layout for your installation. If you are already familiar with watermakers without an energy recovery device like the Clark Pump, please try to forget what you know, as much won't apply to this system and may lead you astray. Please read the instructions and don't make assumptions based on older types of systems.

Here is a simplified drawing of the *SolarMaax 340* layout to familiarize yourself with how the major components interconnect.



**Figure 1: Simplified Component and Plumbing Layout**

When installing the SolarMaax 340 in your boat; here are the top factors to consider:

- A. Make access for service, removal, and repair as easy as possible
- B. Minimize the use of right-angle fittings to reduce water flow drag
- C. Water will spill when servicing filters. Do not mount over sensitive equipment
- D. Keep wire runs as short as possible and oversize the wire to minimize voltage drop
- E. Though quiet for a watermaker, consider the noise when placing the components
- F. Factory sealed membrane element(s) are shipped separate. Keep sealed and install just before use. See Membrane Replacement, page 39, for installation instructions.

# INSTALLATION INSTRUCTIONS

Prior to beginning the actual **installation** process, please **read the entire** installation procedure and take a moment to consider the following installations notes to insure the best performance, life, ease of operation, and maintenance of your *SolarMaax 340* system.

Every boat is different, if any questions arise, please contact us via email ([support@electromaax.com](mailto:support@electromaax.com)). We are here to help you, so there's no need to proceed with the installation if you have any doubts or questions. We would much rather walk you through any questions you have now, than after everything is mounted in place and screw holes are drilled into your boat! **In this Manual, step by step instructions are numbered, Notes are lettered.**

## Installation Notes:

- A. When selecting a mounting location, consider the parts that will require periodic **access**, such as the Pressure Relief Valve on the Clark pump, pre-filters, membrane replacement, flush filter and service valves.
- B. The boost/feed pump requires a 25AMP fuse or breaker for 12 VDC, 15 amp for 24 VDC.
- C. Both the high pressure and low-pressure water lines must be **routed** through the boat in such a way that does **not** expose them to chafing or with tight radius bends that could cause the lines to kink and inhibit flow.
- D. Use only Teflon tape or Loctite #55 sealing cord in the installation of any water line fittings and do not coat the first thread. Pastes type sealants are more likely to get into the system and cause damage to the membrane and Clark Pump
- E. The RO membrane can have its performance degraded by **exposure** to temperatures above 113°F (45°C). Select a mounting location where it will not be exposed to ambient temperatures more than 113°F (45C) when the *SolarMaax 340* is non-operational. If operating and being cooled by sea water, higher ambient temperatures up to 120°F (49°C) are tolerable.
- F. All the assembly inlets and outlets are **labeled** clearly in the manual making the assembly process as “**plug and play**” as possible. Refer to the installation schematic for a detailed pictorial flow chart of the assembly.
- G. As with most projects on a boat, the key to a good installation is **planning and component layout**. We recommend that the components first be loosely (**dry fit**) in place for **verification of how the plumbing will go** before permanently mounted.
- H. Avoid sharp 90 degree fitting turns. The shortest length of tubing between two components may not be the most efficient if it must have hard 90-degree fittings. A longer but smoother turning tube has less flow drag.
- I. **The electrical connections should be performed by a person with proper knowledge and experience in the installation of 12 and 24 vdc systems.**
- J. Voltage drop at the unit will degrade performance. Use the recommended wire size or larger.
- K. For further assistance, email first to bring our techs up to speed with the issue at [support@electromaax.com](mailto:support@electromaax.com)

# COMPONENTS IN ORDER OF WATER FLOW

In this section, each component's function and how it is installed is explained.

## INTAKE SEACOCK:



**Figure 2: 3/4" Intake Seacock and Scoop, Owner supplied**

Install a dedicated 3/4" seacock with a forward-facing scoop, placed as low and in the middle of the boat as possible. Avoid placing the seacock near or downstream of a head outlet or sink drain. Have a yard do the installation during a haul out. Sharing a through hull with another system is not recommended, but in certain cases is acceptable. Use 3/4" hose barbs that match the valve material and 3/4" ID hard walled reinforced below waterline rated hose leading to the Sea Strainer. The Seacock and Hose are not included in the *SolarMaax 340* kit.

## SEA STRAINER:

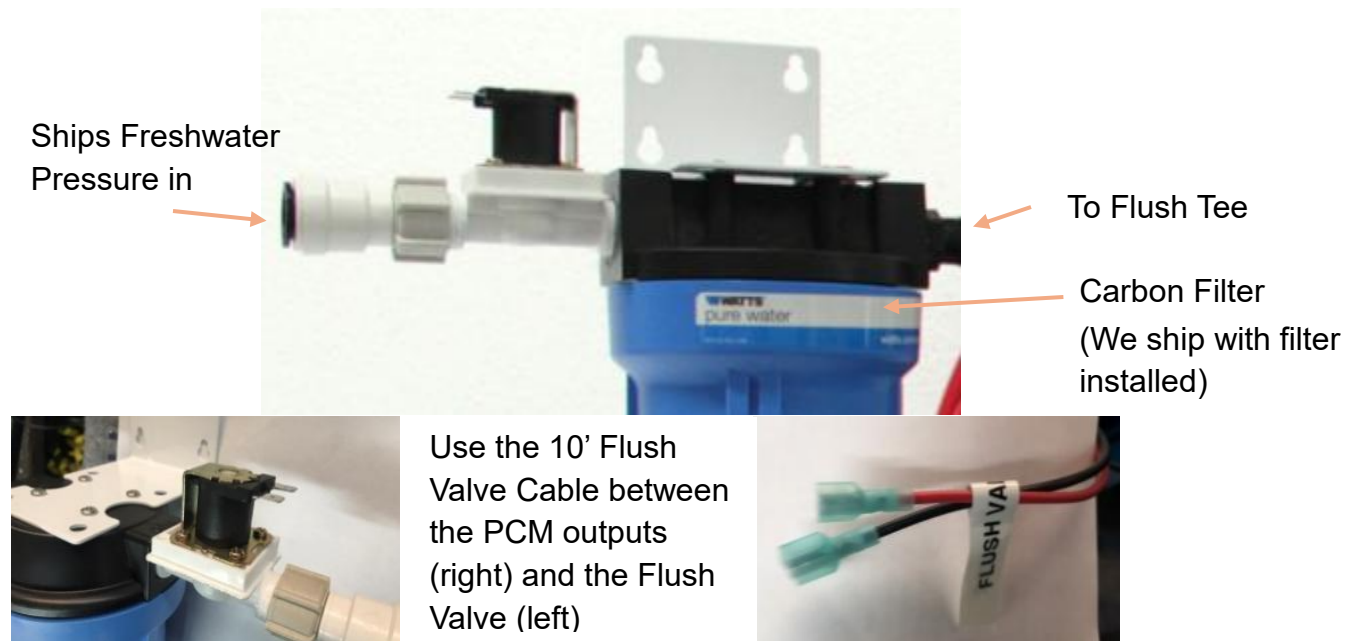


Arrow on housing shows flow direction

**Figure 3: 3/4" Sea Strainer and Mounting Bracket**

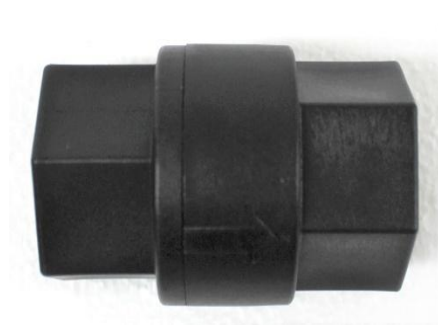
The Sea Strainer is used to protect the check valves in the Feed Pump from being jammed by debris. The Sea Strainer is placed between the Intake Thru-hull Valve and the Flush Water Tee or the intake Service Valve, whichever is placed next in line. Ideal placement is just above the waterline. Use 3/4" hard wall reinforced rubber hose between the Intake Through Hull and Sea Strainer and double clamp the hose connections. If mounted below the waterline, use the reinforced water hose with double clamps from the strainer to the next fitting mounted above the waterline. Make sure there is enough room below the bowl for removal clearance. Water will be spilled when servicing; avoid mounting over sensitive equipment. After selecting a location, screw down the mount bracket. Identify the flow direction by the arrow on the housing then install the hose and tube fittings through the bracket into the strainer body. The fittings hold the strainer body in the bracket. When servicing the strainer, be careful not to lose the bowl gasket. Make sure the Strainer Bowl is screwed tight, so no air is allowed to enter.

## FRESHWATER FLUSH ASSEMBLY:



**Figure 4: Freshwater Flush Assembly**

The Auto-Flush function is used to flush seawater out of the system after use. A carbon filter is used to remove any chlorine that may be in the ship's water tank that will damage the membrane. Mount **vertically** using the integral mounting bracket. Be sure to leave at least 2 inches **below** the assembly to allow for opening filter housing. Freshwater will be spilled during filter replacement. The inlet is connected to the ships pressure water system with owner supplied hose/tube and Tee-fitting to match the ships plumbing. The outlet from Flush Filter is plumbed to a Tee placed in the feed line before the feed pump. Replace the Carbon Filter every 6 months of use or when the system is brought out of long-term storage. **The connections to the electrical "Flush Valve" at the Flush Filter Assembly are NOT polarity sensitive.** The wires can connect to either spade at the valve and the PCM.



The Flush Check Valve keeps the pressurized filtered flush water from going out the intake through hull and directs it to the Feed Pump. Ideal placement is close to the Flush Tee so there is no place for salt water to sit between the valve and the Tee. Fittings included allow for an inline placement or connected directly to the Tee using the 3/4" NPT to Stem fitting that will push into the Tee making it a single assembly.

**Figure 5: Freshwater Flush Check Valve**

## FEED PUMP ASSEMBLY:

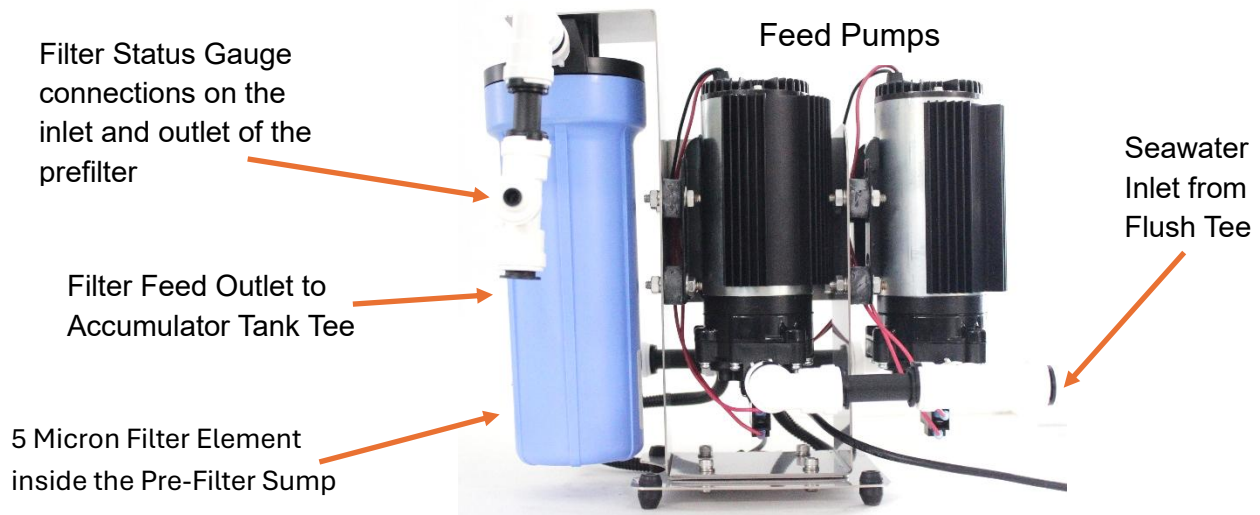
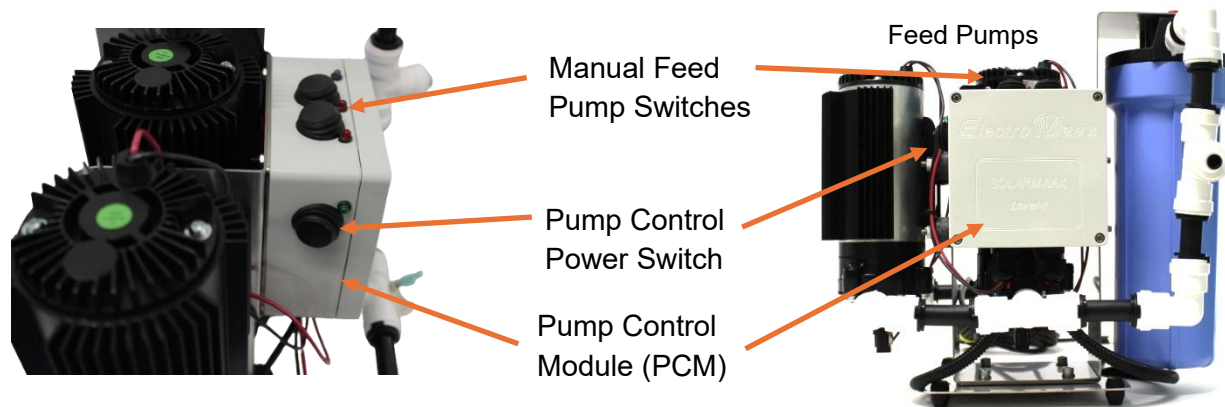
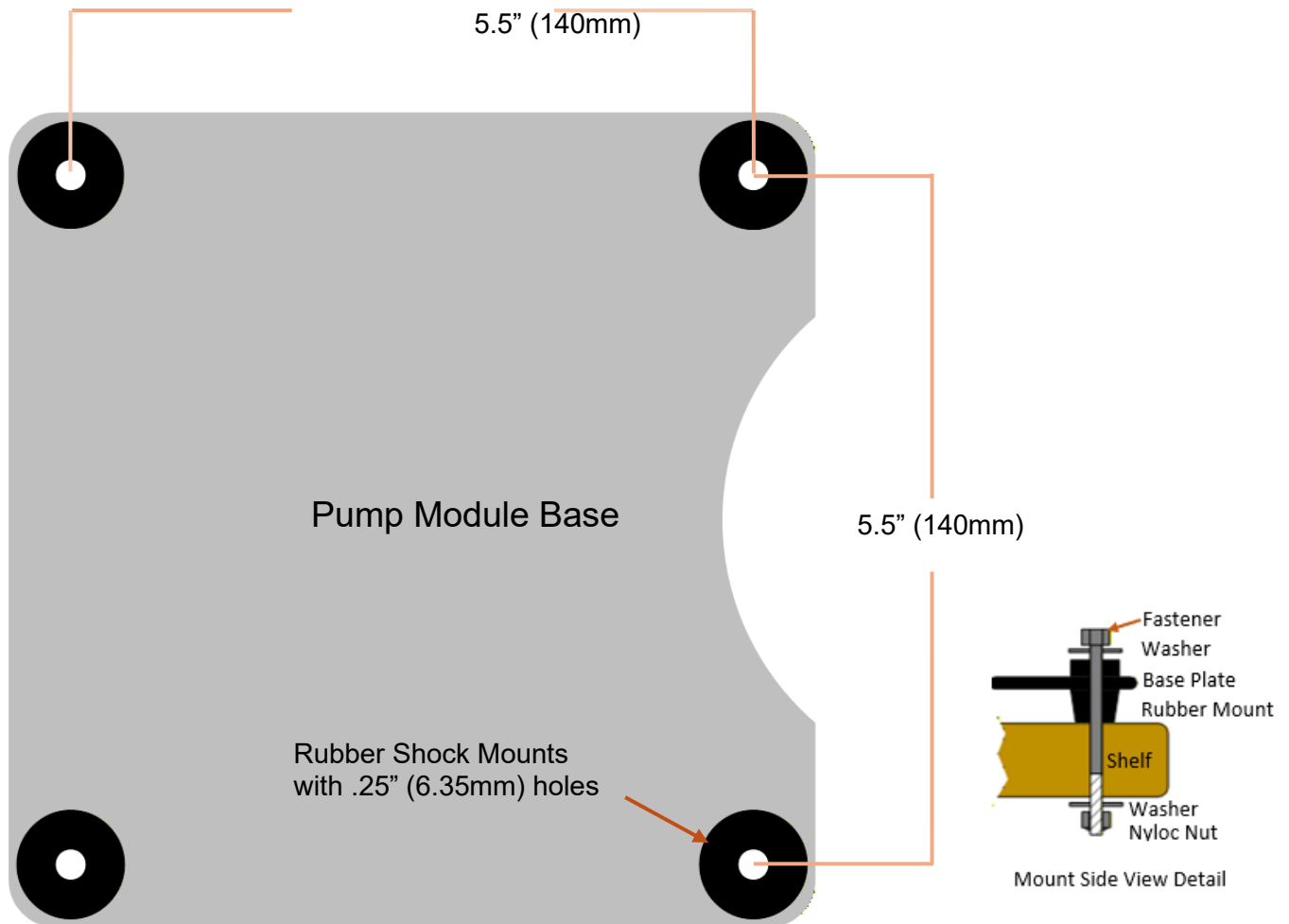


Figure 6: Feed Pump Assembly



The Pump Assembly has a 3 chambered positive displacement diaphragm Feed Pumps, a 5-micron prefilter. The pumps are similar to marine and RV demand pumps but generates higher pressure. They are self-priming but can't prime if the outlet is under pressure. The *Pressure Relief Valve* on the Clark Pump **must be open ½ turn CCW** for the Feed Pump to prime. Mount on a horizontal surface in a dry location with access to the manual pump switches, room for the pre-filter wrench to loosen the sump and enough space in front of the control box to remove the cover to access the electrical connections. Have enough space around it to dissipate the heat and/or place vents below and above the pump to allow for convection currents to take away the heat. If the components must be separated, mount the pump with the pump head down, the Prefilter with at least 2 inches of space under the Sump and the Pump Control Module in a dry area close to the Feed Pump.

## MOUNTING THE FEED PUMP ASSEMBLY:



**Figure 7: Feed Pump Assembly Foot Mount Drawing**

The Pump Module is design to mount on a horizontal surface that can handle water spillage. To mount the Feed Pump Assembly, set the Pump Module in the desired location and use the base as a pattern marking through the holes in the rubber mounts. Remember to leave enough space in front of the Pump Control Module to access the fuses and wiring connections plus access for the filter wrench to the prefilter housing. If mounting in a tight enclosed space, make sure there are vents in the upper area and lower area of the locker, preferably on opposite sides, to vent heat from the feed pump. Use round or hex head ¼" or 6mm stainless steel bolts or screws suitable for the platform material. If bolting, use Nyloc nuts over flat washers. Place washers under the heads of the fasteners to bare on the rubber mounts to keep the heads from pulling through the rubber mount. Tighten the screws or bolts just enough to have the rubber mounts lightly touch the shelf, don't crush the rubber mounts. The bolts won't be very tight so the use of Nyloc nuts is important to keep them from vibrating loose.

## FILTER STATUS GAUGE:



Figure 8: Pre-Filter Status Gauge

The Pre-Filter is equipped with a “Status Gauge” to indicate when replacement is required....it is connected using ¼” tubing to both the inlet and outlet of the Pre-Filter. Note flow direction through Status Gauge. Mount where it can easily be seen during operation. Double sticky foam or Alien tape works good for mounting or can be fastened to a bulkhead.

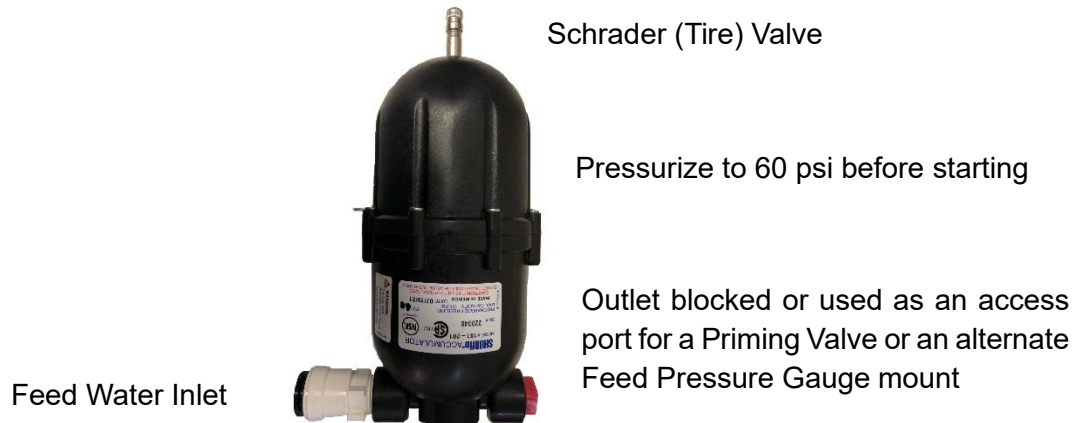
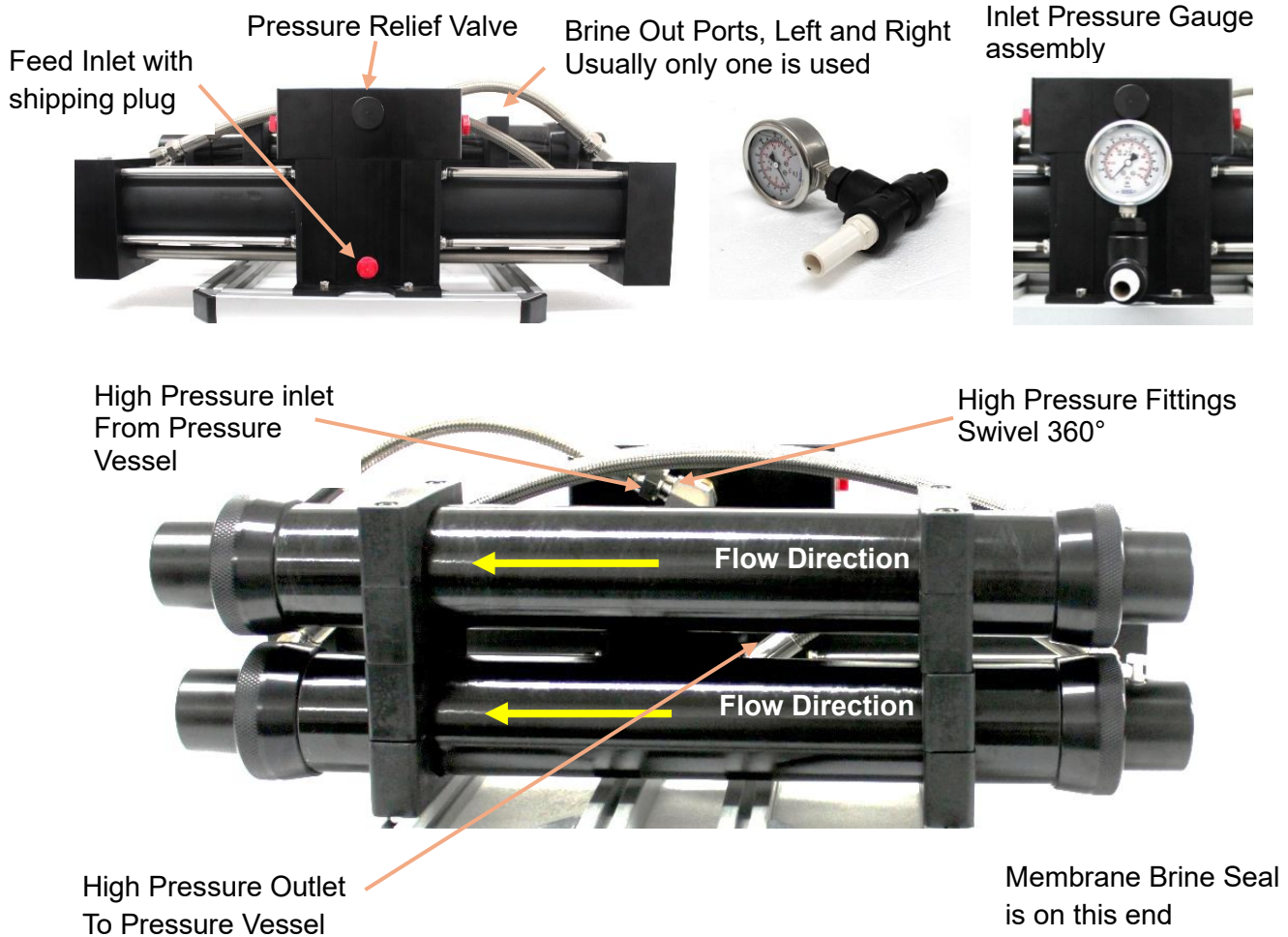


Figure 9: Accumulator Tank

## ACCUMULATOR TANK:

**The Accumulator Tank must be pressurized to 60 psi before use.** It is Teed from the feed tube between the Pre-filter and Clark Pump. Water flow goes in and out, not through. Mount in any position so the Schrader Valve (bicycle tire valve) is accessible to check pressure. It is used to smooth out the feed flow to the Clark Pump when it “shifts” and reverses direction internally. It absorbs pressure spikes during a shift which can affect the pressure switch on the Feed Pump. Due to shipping restrictions, the Accumulator is not pressurized and requires being pressurized to 60 psi (4 atm). Use a bicycle pump to fill to a higher pressure and then use an accurate tire pressure gauge to set to 60 psi. If the Clark Pump shifts are affecting the Feed Pump, check the pressure while the system is off and the Pressure Relief Valve on the Clark Pump is open.

# ENHANCED CLARK PUMP



**Figure 11: Rear view**

The Feed Pressure Gauge is shipped separately. Mount The Gauge to the inlet port as shown using the Teflon Tape provided. Plastic Pipe Threads are only threaded in snug and will bottom out and leak if over tightened. Locate the Clark Pump and Membrane Assembly for easy access to the Pressure Relief Valve and access to the Pressure Vessel for Membrane replacement. The Clark Pump can be mounted in any orientation but if the Pressure Vessel is mounted vertically, the inlet of the Pressure Vessel needs to be on the bottom to purge air out the top. The Clark Pump has two brine discharge ports to choose from. Both are plugged at the factory for shipping. Remove the plug from the one that best suits the plumbing arrangement and leave the other side plugged. The Pressure Relief Valve is all plastic and is only finger tightened. **Do not over tighten.** Leave the Pressure Relief Valve open CCW ½ turn for the initial commissioning. **Before first start up, have the Black Feed Tube to the Clark Pump ready but do not connect yet. The first water through the system is discarded to purge any possible debris before connecting to the Clark Pump.**

# PRESSURE VESSEL & RO MEMBRANE

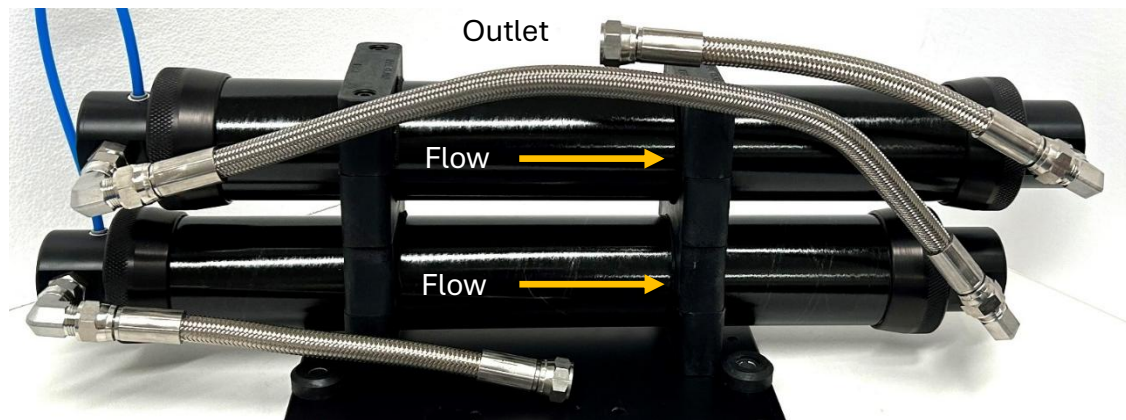


Figure 12: Pressure Vessel and RO Membrane Assembly

**Important!** The RO Membrane Elements are shipped separately in factory sealed bags. Install them into the pressure vessel(s) just before commissioning. The Membrane element(s) should never be allowed to dry out. Follow the Membrane Replacement instructions, page 37, to install in the pressure vessel(s). On first start up, the residual storage solution needs to be purged before making water.

The Pressure Vessel with the RO Membrane inside it, is designed to be as compact as possible for tight installations. It is specifically designed for low water flow drag for energy efficiency, minimal metal exposed to saltwater and ease of membrane replacement. If mounted with one end up, place the Inlet end below the Outlet end with the flow going uphill to help purge air. The stainless-steel flare fittings threaded into the plastic end caps have straight threads and O-ring seals. They are only lightly tightened into the plastic after they bottom out, **completely burying the O-Ring**. Do not over tighten! If there is a leak between the fitting and the endcap, there is a problem with the O-ring seal. *Tightening will not help.*

The Product Outlet End Cap can be positioned at either end as desired. See **Membrane Replacement**, page 36, for end cap removal and reinstallation. The Product Outlet Fitting is a 1/4" Push to Fit for the product tubing. There is a 1/4" plastic plug in the product port for shipping. Remove it just before connecting the product tube during installation. Do not let a membrane dry out.

The flow through a Pressure Vessel/Membrane is directional due to a "Brine" seal placed on one end of the membrane to make it the inlet end. The seal directs the flow through the membrane and stops any flow around the outside. If the placement of this seal is somehow lost, remove one end of the Pressure Vessel. Grasp and shake the end of the membrane. If it wobbles around easily the seal is at the other end. If it hardly moves the seal is at that end.

# OPERATOR CONTROL PANEL

The **SolarMaax 340** is equipped with a basic electronic control system with a manual override. The manual override allows for emergency operation of the system in event of an electronic failure. The Operator Control Panel (OCP) communicates with the Pump Control Module (PCM) to control the Feed Pumps and Auto Flush Mode as required. The manual control is on the PCM.



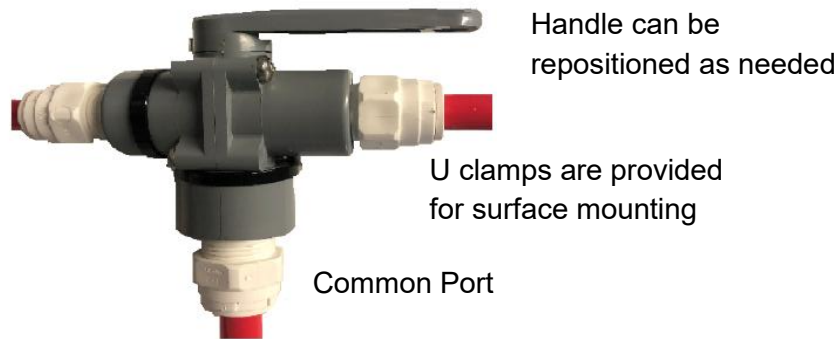
**Figure 13: Owner Control Panel (OCP)**

OCP has the following features / functions, interfacing with the Pump Control.

- Pump ON / OFF button with LED to indicate motor status
- Manual 3-way valve to direct product flow to tank or testing port
- Analog flow gauge
- Product test port
- Auto Flush control with indicator LED

The Control Panel is surface mounted using the supplied standoffs or flush mounted. Place it so it is easily accessed, and the test port tube can be led to drain somewhere safe. For ease of service, the Panel and the 3 Way Service Valves should be located close to each other so all three Service Tubes can reach the Service Pail.

## 3-WAY SERVICE VALVE



**Figure 14: 3-way Service Valve**

Two 3-way service valves are provided for access to the seawater Feed Line and Brine Discharge Line. They are used to facilitate membrane storage and cleaning procedures. They should be placed so their alternant Service Tubes can reach a Service Pail at the same time.

- A. The Intake Service Valve can be placed anywhere between the strainer and the Feed Pump. It can be hard mounted directly to the sea strainer with the fittings supplied. **The Intake Tubing and the Intake Service Valve should not be mounted higher than the top of the Feed Pump Module for ease of priming the system.**
- B. The Discharge Service Valve is placed anywhere in the Brine Discharge Line including mounting directly on the Clark Pump brine outlet port.

**Note:** The valve will always introduce a 90-degree turn in the water flow. There is no straight through position.

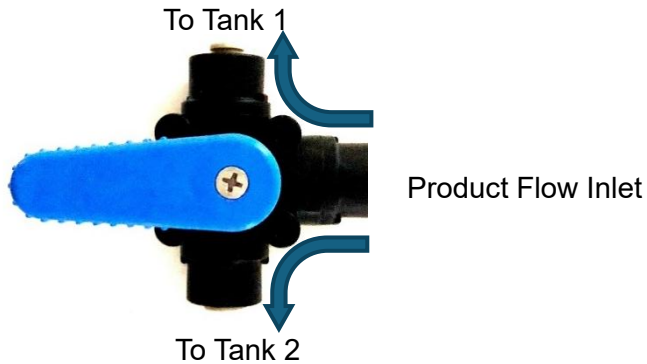
## DISCHARGE THROUGH HAUL



**Figure 15: Brine Discharge Through Haul Fittings (Owner Supplied)**

The red Brine Discharge Tube from the 3 way Brine Service Valve is led to a dedicated Owner Supplied through 1/2" hull fitting just above the waterline. It is possible to tee it into an existing drain above the waterline but there is a good chance it will cause gurgling noise and flood the boat if the drain through hull valve is closed. Sharing a discharge is highly discouraged for those reasons.

## TANK FILL SELECTOR VALVE



**Figure 16: Optional Tank Fill Selector Valve**

If more than one tank needs to be filled, a Product Water 3-way Valve can be installed in the product line from the panel. A Product Water 3-way Valve is a specific type of valve that cannot block the Product flow in any valve position (non-dead heading)

**Caution: Do not use any type of selector valve that can block the flow in any way, even momentarily, or damage to the system will happen.** The valve can be mounted in a panel or fastened to a wall by drilling out the mounting holes.

## TDS TESTER AND TESTING PRODUCT WATER QUALITY



**Figure 17: Handheld TDS Test**

A good RO membrane will produce product water that is well below the upper limit of 500 parts per million (ppm) of Total Dissolved Solids (TDS) of which is mostly salt in seawater. On startup, the first flow out of a membrane that's been operating in saltwater will have a high TDS reading (taste salty) because of osmosis inside the membrane while it's been depressurized. The first low-quality water will quickly be flushed out so there is a waiting period after start-up to test the product. The Held Salinity/TDS meter can accurately determine the quality of the product water and be compared to an actual "taste" test. For most people a simple taste test is sufficient to determine if the water is drinkable. Most people can start to taste the salt when the TDS is getting close to the upper limit of 500 ppm, but some cannot taste it even if it's well above 500 ppm and would not be considered good. To "TEST" the product, do the following steps on the next page.

## HANDHELD TDS TESTER MEASUREMENT INSTRUCTIONS:

1. Start and run the system, making, and diverting the product water, for at least a minute.
2. Remove the protective cap.
3. Turn the TDS meter on. The ON/OFF switch is located on the panel.
4. In a clean cup, **rinse 3 times** then take a sample to about 2.5" deep.
5. Immerse the meter into the water/solution up to the max. Immersion level (2").
6. Lightly stir the meter to dislodge any air bubbles.
7. Wait until the display stabilizes. Once the reading stabilizes (approx. 10 seconds), press the HOLD button to view the reading out of the water.
8. If the meter displays a flashing "x10" symbol, multiply the reading by 10.
9. After usage, shake off any excess water from your meter. Replace the cap.
10. If the water reads below 500 ppm, turn the Product Diversion Valve to TANK

If the water isn't below 500 ppm or the water tastes bad, let the system run for ½ hour and test again. If the water quality continues to be poor, the membrane will need to be cleaned or replaced. See membrane cleaning and replacement sections.

If the system has been flushed with freshwater after use (recommended) the first water will not be that salty and should clear quickly. If it has been sitting with saltwater even for a few minutes, the first flow will be very salty and should be diverted so it doesn't go into the tank.

**Warning:** In a Level 1 system where there is no automatic salinity sensor/diversion valve capability which always tests the water, a manual TDS test with the Tester or a taste test should always be done on every start up just in case something has gone wrong with the membrane. If the product is drinkable at all, the membrane is rejecting all harmful pathogens.

**Warning:** If operating in freshwater, testing the Product Water with the Handheld TDS Tester should read 10 ppm or less of TDS if the membrane is functioning well. A "Taste" test is not reliable when operating with a freshwater feed. If the membrane is damaged enough to let a pathogen through it will show up as very high TDS in the product water while operating in saltwater but **not in freshwater**. A UV Product Water Sterilizer is recommended for continuous freshwater operation.

## PURE SILICONE GREASE PACKET:

Use only pure silicone grease for lubing components when needed. A grease packet of the proper type of grease is provided.



# MOUNTING THE COMPONENTS

- A. Dimensions for the Clark Pump Assembly and the Feed Pump Module are on page 42
- B. Follow the Complete Plumbing Diagram on page 23 and the mounting notes in the component descriptions. Note how the 3-way valves are plumbed, **they will always introduce a 90° turn in the flow.** A set of U brackets are supplied to mount the valve to a bulkhead if desired.
- C. When mounting the components, check the thickness of the bulkhead and cabinet panels and size the fasteners appropriately. If using through bolts, use Nyloc nuts and washers. Use fasteners that match the mounting holes in the components or one size under at most.
- D. The length of the feed and discharge tubes do not affect the performance, but many right-angle turns will. Long sweeping turns are better.
- E. Place the Enhanced Clark Pump/Pressure Vessel assembly for easy access to the Pressure Relief Valve while operating the system and with consideration for how to replace the membranes which means either there is enough room off of one end of the Pressure Vessel to remove the membrane in place or the Pressure Vessel needs to be removed to allow access. Allow wrench access to the High-Pressure fittings at the ends of the Pressure Vessel for removal. The HP fittings require 2 wrenches for assembly or removal. The flexible HP hoses and the swivel fittings in the Clark Pump allow for more installation options for fitting access.
- F. The 3-way Service Valves (one is in the Operator Control Panel) should be located in the same area where a Service Pail can be securely placed and the Service Tubes can all reach it at the same time. This is important for ease of use and maintenance. The Service Tubes can be removed when not in use. **The Feed Tubing and the Intake Service Valve should be mounted below the top of the Feed Pump Module. The Brine Discharge Service Valve is not as critical but should be mounted close to the level of the Feed Pump Module.**
- G. Place the Operator Control Panel in an area that has easy access, and the Sample Tube can reach a place where it can drain away the sample product water and reach the service pail. The Sample and Service Product tube can be the same one or two different lengths if needed. The tubing is easily swapped using the push to fit fitting on the panel.
- H. The Product water must be dropped into the top of the tank without any back pressure. Do not connect it at the bottom outlet of the tank as the head pressure may try to push product water backwards through the membrane. Tee into the tank vent line or add a port into the top of the tank.
- I. Make sure the tank vent is not clogged. If the tank is overfilled, the product will flow harmlessly out the vent.
- J. The Feed Pump Assembly should be mounted to a rigid horizontal surface in a dry area close to the waterline and the power source with good access to the Pump Control Module and Prefilter removal using the Filter Tool. Water will be splashed when the Prefilter is removed.
- K. The Brine discharge tubing after the Brine Service Valve should rise above the waterline by at least a foot then run to a brine discharge through hull mounted just above the waterline, typically in the boot stripe.

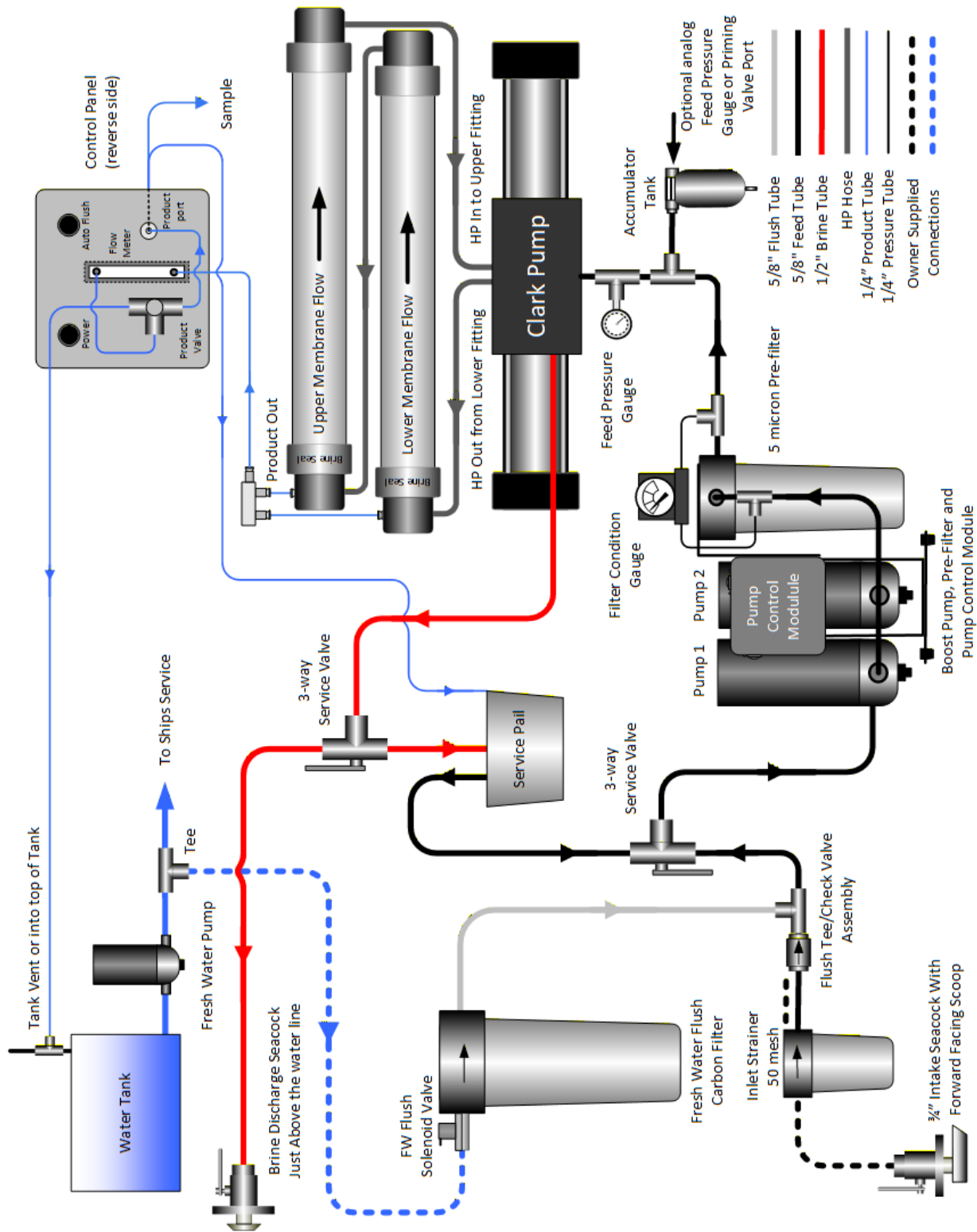


Figure 18: Complete Plumbing Diagram

## LOW PRESSURE TUBE AND FITTINGS:

### Plastic Pipe Threads:

Use 3 to 4 wraps of Teflon Tape on the threads, leaving the first thread bare. Tighten fittings until snug. Over tightening will bottom out the fittings and leak. If a pipe thread is too loose and bottoms out easily, use Loctite 55 thread cord to build up the threads.

### Tubing Color Coding:

The **low** pressure (pressures listed on chart pg.7) tubing has been **color coded** depending upon where it is used in the system. All plastic tubing is linear low density *polyethylene* tubing (LLDPE) approved for drinking water use.

**Black 5/8" tubing** is used for the raw water plumbing from the outlet of the ship's sea strainer to the inlet of the Clark Pump.

**Red 1/2" tubing** is used for the brine discharge from the Clark Pump to the discharge through hull.

**Blue 1/4" tubing** is used for the freshwater product discharge from the RO membrane assembly which is led to the Control Panel then to the ships water tank or Service Pail through the Product Diversion Valve on the Panel.

**Black 1/4" tubing** is used to plumb the Feed Pressure Gauges from the fittings on the inlet and outlet of the Pre-filter.

**Clear 5/8" tubing** is used from the carbon filter to the Tee in the feed for the freshwater flush.

### TUBE CUTTER:

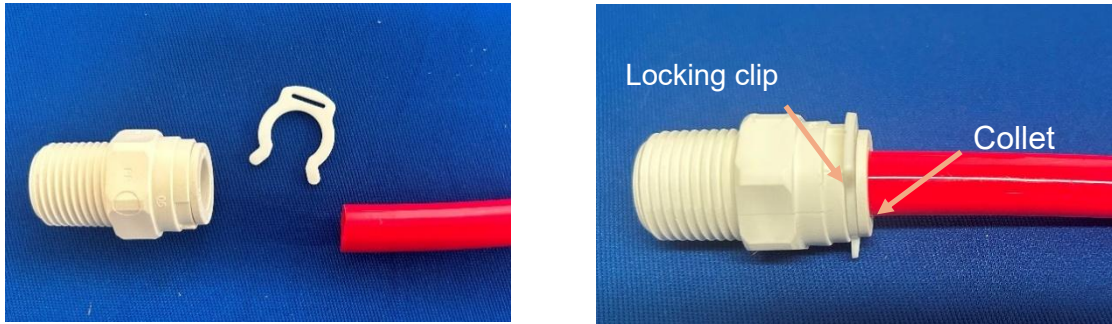


**Figure 19: Tube cutter**

A tube cutter is supplied with every **SolarMaax 340** system. This cutter allows the tubing to be cut squarely to allow for a leak free seal on "**Push-to-Connect**" fittings. The above photo shows the correct placement of the tubing into the tubing cutter. The cutter has a **hinge** on one end and once the tubing is placed in the cradle the ends are **squeezed and rotated** together to cut the tubing. Breaking the cut OD edge with a fingernail or other tool can help assembly.

## TUBING CONNECTION:

All low-pressure fittings are “**Push-to-Connect**”, high grade, double “O” ring, NSF 58 certified, lead free, polypropylene G.A. Murdock fittings. The **SolarMaax 340** system comes with the push-to-connect fittings pre-installed on the larger components. Additional fittings are supplied to be able to customize installation as needed. The figure below shows the “Push-to-Connect fitting, locking clip, and tubing.



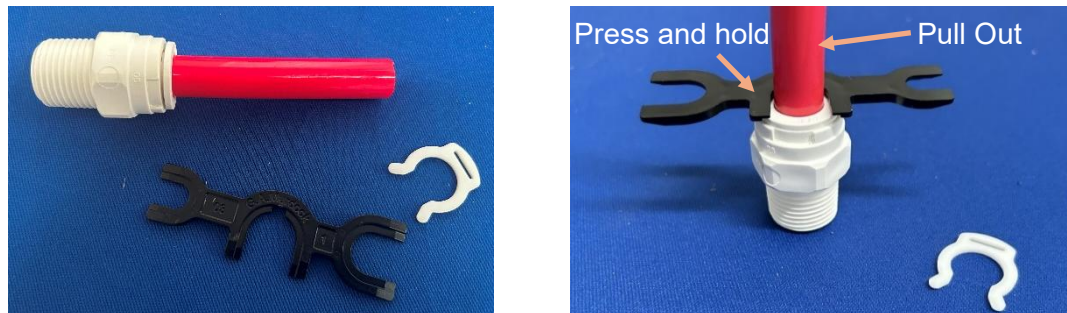
**Figure 20: Fitting, Locking Clip & Tubing Installation**

### Tubing Installation:

The tubing is **pushed** into the fitting until the tubing seats onto the internal stop of the fitting. The tube goes in easily then push hard to get past the collet and the O-ring seals. The collet keeps the tube in. The locking clip is installed between the body and the collet to prevent accidental tube separation.

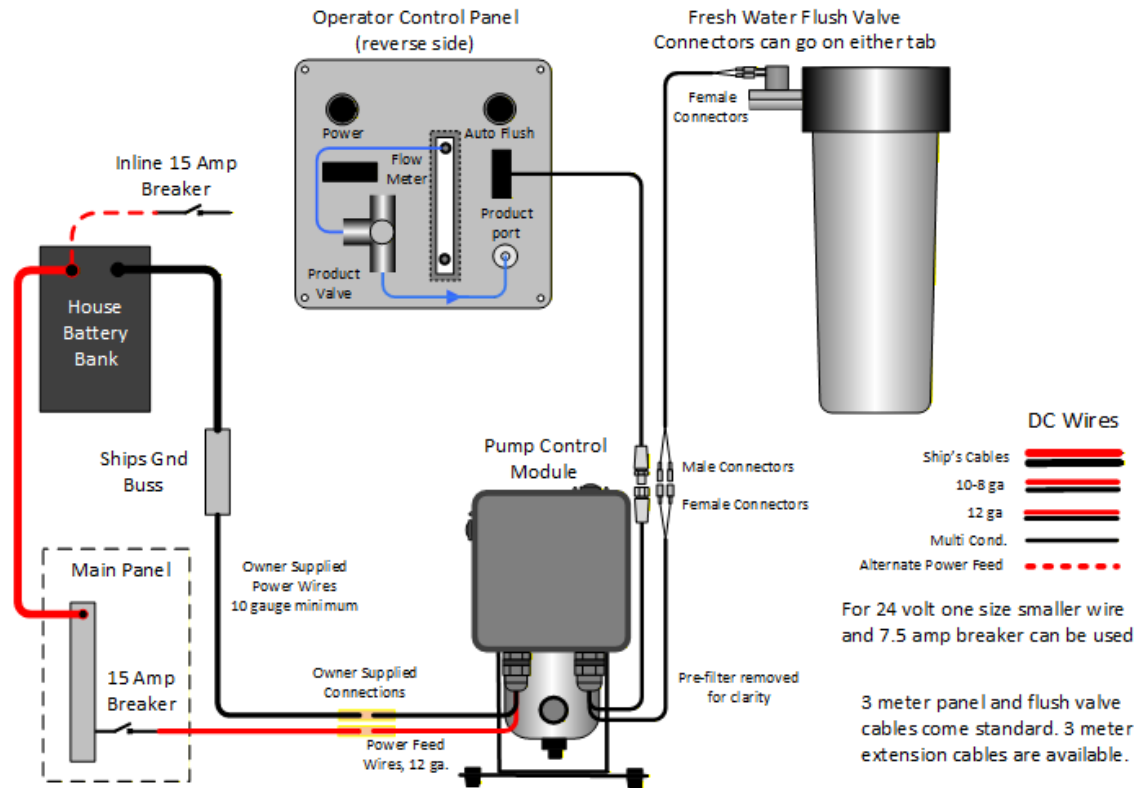
It is **recommended** that tubing installations are inspected at least annually, and parts replaced as needed.

### Tubing Removal from Fittings:



**Figure 21: Tubing Removal Assist Tool**

To **remove** the tubing from the fitting the locking clip **must** be removed. Using the Tubing Removal Assist Tool, **press** the notched side of the proper size opening against the collet of the fitting and while holding the collet up against the fitting evenly, then **pull** on the tube to remove. Fingers can be used to push the collet down but it's easier using the tool. **On the feed and flush tubing before the Pump module, if a tube must be disconnected, it is recommended to replace the tube or cut an inch off to always have an unused connection in the suction side of the system.**



**Figure 22: Electrical Diagram**

Proper wiring is important to minimize voltage drop between the batteries and the Feed Pump. Use Marine grade tinned multi strand wire. Pick one of the methods above, taking power from a breaker on the panel or wire an inline breaker directly from the house batteries, whichever is closer. Use 10/12-gauge yellow butt connectors with heat shrink. If wire size 8 gauge or over is needed, place a covered power terminal strip sized for the larger wire by the PCM to make the connections.

Wire gauge size between the power source and the SolarMaax PCM:

(Note: Consult Current ABYC Wire Size Tables)

10 gauge for distances up to 10 feet

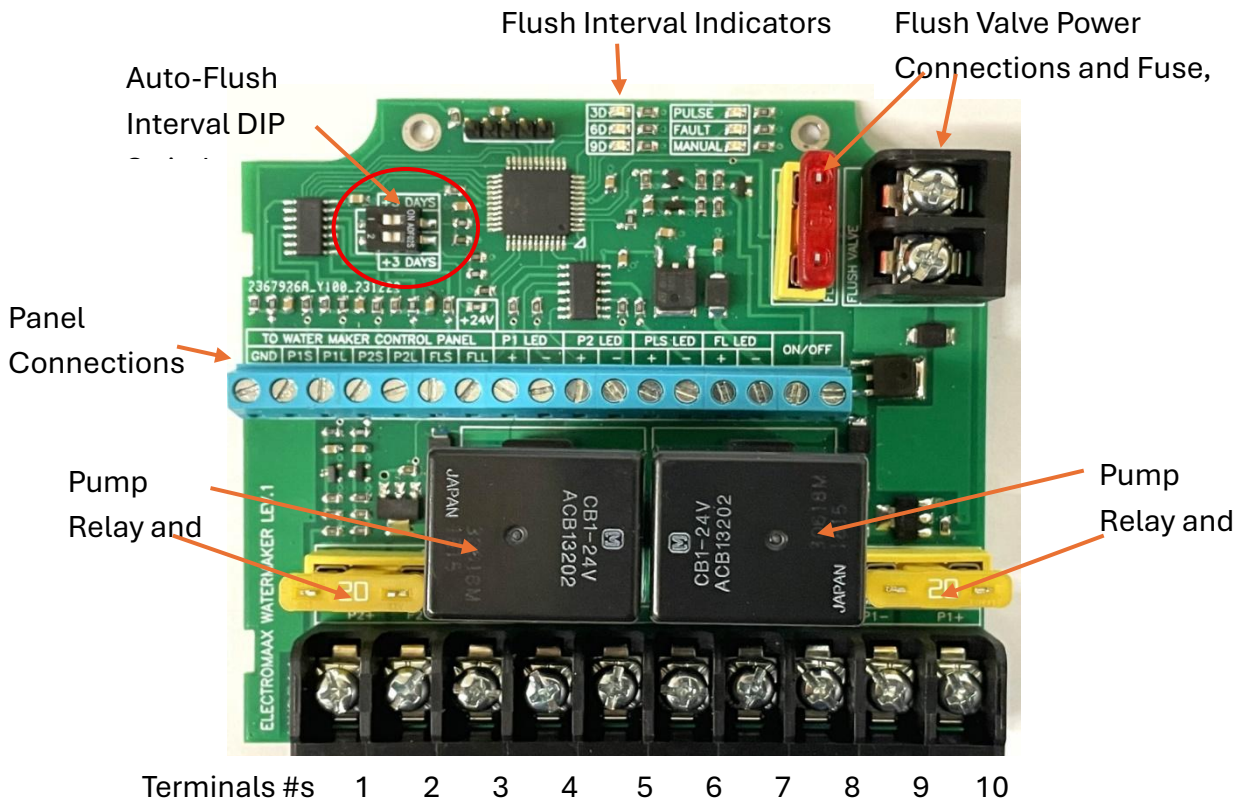
8 gauge up to 20 feet

6 gauge up to 40 feet

The connection between the OCP and the Pump Control Module (PCM) is via the black cable which is mated with the corresponding 6-pin push and screw (CW) connector. The Flush Valve cable attaches to the two wires with female spade terminals coming through the small gland and connects to the Flush Valve on the Carbon filter. 10' extensions for both cables are available for purchase through ElectroMaax.



**Figure 23: Operator Control Panel Cabel Connector**



**Figure 24: Pump Control Circuit Board**

Working from left to right these are following connections points:

- |                                 |                                 |
|---------------------------------|---------------------------------|
| <b>1 - P2+</b> Pump 2 positive  | <b>6 - B+</b> Battery positive  |
| <b>2 - P2-</b> Pump 2 negative  | <b>7 - B1</b> Button 1 (Pump 1) |
| <b>3 - B-</b> Battery negative  | <b>8 - B1</b> Button 2 (Pump 1) |
| <b>4 - B2</b> Button 2 (Pump 2) | <b>9 - P1-</b> Pump 1 negative  |
| <b>5 - B2</b> Button 2 (Pump 2) | <b>10 - P1+</b> Pump 1 positive |

## CONTROL SYSTEM:

### Pump Control Module (PCM level 1: Remote Pump Operation and Flush)



**Figure 25: Pump Control Module (PCM)**

#### Control Operation:

Turn on the power feed from the ship's batteries. Test Manual Feed Pump function by momentarily activating each Manual Pump Power Switch on the top of the PCM enclosure. Activate the Power Switch on the side of the PCM enclosure. An LED by the switch will flash when the power is on. The LED has three states:

*ON (Flashing 1 / sec.) - system is operating normally*

*ON (Steady) – Electronic failure - unit requires factory repair*

*OFF – when switch is on, no power supplied to the PCM*

#### Manual Feed Pump Control Switches:

The system is provided with a manual Feed Pump control capability in the event of any electronic problems. This ensures the owner can “make water” if the electronic components are compromised. Power to the pump runs directly through these switches. It can be convenient to use these switches to run the system during priming and servicing instead of the OCP Pump Power Switch.



**Figure 26: Operator Control Panel Detail**

### **Pump Power Switch on the OCP:**

The Feed Pumps and Flush function are remotely controlled by the Panel switch. The Power Switch on the PCM activates the Panel switches

### **Freshwater Flush: (Auto and Single)**

It is recommended to fresh water flush the system after use. There are 2 flush modes available: *Auto and Single*. The Flush process activates the Boost Pump and a Solenoid Valve on the Carbon Flush Filter, injecting filtered freshwater from the vessel's pressure water system to flush out the saltwater. The Pump Power Switch needs to be off before starting a flush.

### **Single Flush:**

A 3 second press of the Flush Button will start a single-event 3-minute flush, the LED will light steady. A Blue LED on the top of the PCM also indicates Auto-Flush status. After the flush the LED goes out.

### **Auto Re-Flush:**

A single push of the Auto-Flush button on the OCP starts a 3-minute flush then re-flushes once every 3 / 6 or 9 days (user selectable). The LED (blue) will light steady during the flush process. After completing the initial flush, the LED will flash slowly indicating it remains in Auto-Flush stand-by mode. A Blue LED on the top of the PCM also indicates Auto-Flush status.

NOTE: A Flush can **only** be enabled when the Feed Pump is off. If a pump switch is turned on during a Flush cycle, the Flush and Auto Flush will be canceled.

### **Deactivating a Flush:**

To cancel the Auto-Flush or a Single Flush press the Flush Bottom again or start the system.

### **Programming the Auto-Flush Interval:**

There are 2 DIP Switches on the circuit board (see figure 24 on page 27). When both are in the off position, the default re-flush interval is 3 days for the tropics. Turning one switch on will add 3 days for a 6-day interval for temperate climates. Turn both on for a 9-day interval for cold northern latitudes. Default: 9 Days.

The Commissioning Procedure should be performed at a new system start up. The main function is to prime the Feed Pump, look for leaks, and purge the system of storage chemicals.

1. Open the watermaker intake and discharge through hull valves.
2. Turn on ships pressure water system. Purge the air from the carbon filter using the button.
3. Set the Intake and Brine Discharge 3 Way Valves to normal run. (See Plumbing Diagram Pg. 23)
4. Set the Product 3 Way Valve to "TEST". Put the Test Port Tube into a container.
5. Open the Pressure Relief Valve 1/2 turn CCW from a finger tight closed position.
6. Place the loose end of the black Feed Tube to the Clark Pump in a container.
7. Turn on the Main Power Breaker (ship's system).
8. Turn on the Power Switch on the PCM to activate the Control Panel functions.
9. Press Flush to start a flush cycle. Look for leaks in the system. If any leaks are found, turn off the system and repair before continuing. Watch for water to fill the container by the Clark Pump.
10. Press the Flush button again to stop the flush and connect the Feed Tube to the Clark Pump. **This one-time step clears any debris between the Prefilter and Clark Pump.**
11. Press the "Pump 1 Power" switch on the Panel to start the Feed Pump 1. Look for water flowing through the Inlet Strainer. When the feed water reaches the Feed Pump, its sound will change and be uneven then smooth out as the air is purged. Pressure will start to build in the feed pressure gauge, and the Clark Pump will make its first "shift" as it starts to circulate water through the membrane. The shifts should start to even out as air is purged. They may be hard to hear, watch for a rise and fall of Feed Pressure as the Clark Pump shifts.
12. With the Feed Pump **running**, make a visual inspection to ensure that the connections are all **leak** free. If any leaks are found, turn off the system and repair before continuing.
13. Turn off Pump 1 Power and turn on Pump 2 Power. Let it purge until it runs smooth.
14. Restart Pump1, continue to run the system unpressurized (Pressure Relief Valve open) for 20 minutes to purge the storage solution from the membrane elements. The Feed pump should be running smoothly now. If not, there is an air leak in the Strainer or Flush systems. Fix before continuing. If the pumps sound doesn't smoothen out there may be a leak in the intake water line.
15. After 20 minutes and the system is running smooth with regular shifts in the Clark Pump, close the Pressure relief valve. The sound of the Feed Pump and the Enhanced Clark Pump shifts will change as high pressure is generated in the Membrane and Product Water will start to flow through the Flow Meter then out the Test Port Tube.
16. Check for leaks at the high-pressure hose connections and around the Clark Pump, Membrane end fittings and Control Panel. Recheck the Feed system for leaks. If leaks are found, stop the unit and correct as needed.
17. Run the system with the Product Water diverted for 10 minutes to purge the Product Water side of the Membrane to clear any remaining Storage Chemical.
18. Test the Product Water with the Handheld Salinity Sensor. If below 500 ppm, turn the Product Valve to the "TANK" position to fill the tank if desired.

## NORMAL START UP:

**Note:** If there is any question about the service history of the system, perform a “Restart after Long Term Storage” (pg. 34) procedure first.

1. Turn on the Ship’s Main and PCM power.
2. Ensure the watermaker Inlet and Brine Through Hulls are open and the sea strainer is free of debris.
3. Turn the Product Water Selector Valve on the Control Panel to the “TEST” position. Place the test port tube where it can drain properly.
4. Open the Pressure Relief Valve on the Clark Pump 1/2 turn CCW **or**, if the system has been recently run and is well primed, the Pressure Relief Valve can remain closed.
5. Turn **ON** one or both “Pump Power” switches. Listen for the Feed Pump to run smoothly and the Clark Pump is shifting normally.
6. Close the Pressure Relief Valve finger tight if opened. Watch for water flow in the Flow Meter, there will be bubbles at first then should clear and the reading settles down to the **rated flow rate**.
7. Wait 1 minute then test the product with the Handheld TDS Tester. If below 500 ppm go to step 8. If not, wait another minute and re-test. If the reading again is high, wait another 10 minutes and re-test. If it fails again and the product flow rate is normal, there could be a problem with the membrane. See the Troubleshooting guide. (Pg. 43)
8. When the product is good, turn the Product Valve to the “TANK” position to fill the water tank.
9. If the water tank overfills, the water will overflow out the vent but should not cause a problem.

## NORMAL RUN:

- A. Using one pump is recommended especially in cold seawater. Use both pumps for max output in warm seawater, Use one pump for best electrical efficiency and life of the pumps, 2 pumps for best water quality and output. Alternate the pumps for one pump operation.
- B. Watermakers like to run. The best practice is to run until the tanks are full, shut down with a freshwater flush, then restart when the tanks are down after a few days. Flushing is important because what biological growth that can happen inside the membrane in saltwater will not survive in freshwater and vice versa.
- C. Monitor the Filter Status Gauge. Filter elements clean better if they are cleaned as soon as they **start**, or even better, before they start to restrict the flow.
- D. In rough sea conditions and hard sailing, watch for air getting into the system causing the feed pump to lose its prime and the feed flow has stopped. Open the pressure relief to allow it to prime again then close. If this happens often, wait until better conditions to run the system. This is more likely to happen if the through-hull is not down by the keel of the boat or excessive boat speed.
- E. Oil in a membrane will ruin it. It’s usually not a problem as oil normally floats on the surface but if an oil slick is encountered at sea in rough conditions it can get into the system. Avoid running the system.

- F. The system can be run from a brackish or freshwater feed source without having to make any adjustments. A good membrane works equally well in fresh or saltwater. The feed pressure will be lower operating in freshwater.

**Warning:** Testing the Product Water with the Handheld TDS Tester while operating in freshwater should read 10 ppm or less of TDS if the membrane is good. A “Taste” test is not reliable when operating with a freshwater feed. If the membrane is damaged enough to let a pathogen through it will show up as very high TDS in the product water while operating in saltwater but **not in freshwater**.

## SHUT-DOWN PROCEDURES:

### NORMAL SHUT-DOWN, NO FRESHWATER FLUSH:

1. Turn off the system with the Pump Power button(s) on the Operator Control Panel. Main and PCM power can stay on.
2. Turn the Product Diversion Valve to the “Test” position.
3. The Pressure Relief Valve can be left closed.
4. Do not leave it unflushed for more than a day without running or flushing.
5. On restart, test the product water before turning the Product Diversion Valve to “TANK”

A watermaker is happiest running for a long time then flushed every time it's turned off but there are times where it shouldn't be flushed. For offshore racing, the watermaker may only be run a short time each day to make the minimum amount of water needed to save weight. Flushing uses about 6 gallons of freshwater so flushing every time after short runs uses up most **or more** of the water just made. Being used every day, fouling is minimal so only do a One Time Flush every 5 days or so on an offshore race after making enough water for it.

### NORMAL SHUT-DOWN WITH A ONE TIME FLUSH:

1. Turn off the system with the Pump Power Button(s) on the Operator Control Panel. A Flush Cycle will not start with a pump on.
2. Important! Leave the Pressure Relief Valve closed during the flush to help limit the flush water flow.
3. **Make sure the ship's Freshwater Pressure System is on with plenty of water in the tank.**
4. A single push of the Auto Flush Button starts a onetime flush cycle. Watch for the Feed Pressure to drop and stabilize at a lower pressure as the saltwater is flushed from the membrane. The LED will be on solid while the Flush is running. A flush uses about 6 gallons. The system is ready for restart.

The **SolarMaax 340** can now sit idle for typically **3 days** before:

- A. The next use.
- B. An additional freshwater re-flush.
- C. Pickling for extended system storage.

## NORMAL SHUT-DOWN WITH AUTO RE-FLUSH EVERY 3 TO 9 DAYS:

1. Turn off the system with the Pump Power Button(s). A Flush Cycle will not start with a pump on.
2. Important! Leave the Pressure Relief Valve closed during the flush to help limit the flush water flow.
3. **Make sure the ship's Freshwater Pressure System is on with plenty of water in the tank.**
4. Press and Hold the Auto Flush Button for 3 seconds to start the first Flush. The LED is on steady during the flush. Watch for the Feed Pressure to drop and stabilize at a lower pressure as the saltwater is flushed from the membrane.
5. After the initial flush, the LED will "slow" blink to indicate it's in Auto Re-Flush mode.
6. The Pressure Relief Valve must be left closed. The system can be restarted as is when needed.
7. On restart, test the product water before turning the Product Valve to "TANK".

If the Feed Pressure remains steady, the flush is not working. Check if the freshwater pressure pump and the flush valve are functioning. The 3-day window is an average because the **rate** of biological growth **varies** with seawater composition and temperature. Use a 3-day interval in hot climates and 9 in cold climates. The freshwater flushing after running helps inhibit biological growth which could lead to Membrane Element fouling.

## PICKLING FOR LONG-TERM STORAGE:

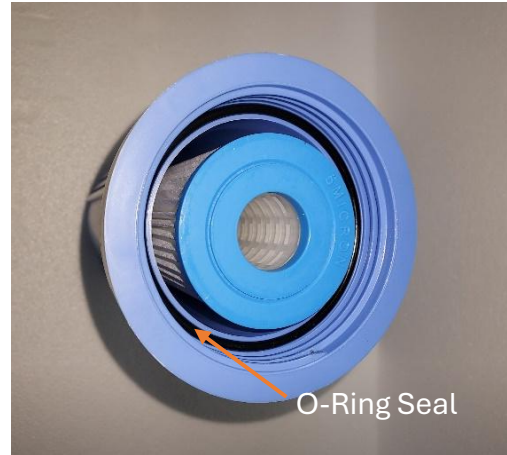
1. Make 2 gallons of product water or pour 2 gallons of distilled water into the Service Pail.
2. Perform a freshwater Flush as detailed in the Freshwater Flush procedure.
3. Wearing gloves, thoroughly mix an 8 oz package of Memstor Storage Chemical into the water in the Service Pail. This may take some time to fully dissolve the powder.
4. Put the 3 service tubes (See Plumbing Diagram pg. 23) into the Service Pail. Secure the tubes if necessary to keep them in place.
5. Turn the Feed and Brine 3-way Valves to their Service positions.
6. Turn the Product Valve to the "TEST" position.
7. **Important! Open the Pressure Relief Valve.** Do not run the System under pressure while circulating the Storage Chemical.
8. Start one feed pump until its primed, stop it and start the other until its primed then run both to circulate the Memstor. Let it run for 20 minutes to thoroughly saturate the membrane
9. While still running, turn the Brine Service Valve back to the Normal Run position. Almost empty the pail but try not to draw in air then turn the system off.
10. Turn the Feed 3 Way Valve back to the Normal Run position.
11. Close the Intake and Brine Through Hulls, drain, clean and dry the Intake Strainer, Pre-Filter and Flush Filter. Reinstall clean or new dry elements.
12. Turn off the Power Breaker and make a label stating when the System was Pickled.

## WINTERIZING:

1. Instead of the Memstor, put 2 gallons of the -100° RV potable water antifreeze into the service pail, then follow steps 4 through 12 for Long-Term Storage. **WARNING:** DO NOT use automotive antifreeze.

## RESTARTING AFTER LONG-TERM STORAGE

1. Open the Intake and Brine Discharge Through Hulls.
2. Check the Intake strainer is clean and the sump tight
3. Open the Prefilter Sump to check for a clean 5 Micron Filter Element. If the filter is wet and smelly the system may have not been Pickled properly or at all. Install a new filter if bad.
4. Replace the Carbon Flush Filter if over 6 months old or age is unknown.
5. Open the Pressure Relief Valve on the Clark Pump 1/2 turn CCW from finger tight.
6. Check the Intake and Brine 3 Way valves are in the Normal Run position.
7. Set the Product Valve to “TEST” and have the Product Service Tube able to drain properly.
8. Turn on the Main Power Breaker and the PCM Power switch on the Feed Pump Assembly.
9. Turn on Pump 1. Check for water flow and Pump 1 running smoothly then turn off.
10. Turn on Pump 2. Check for water flow and Pump 2 running smoothly then turn off. Restart Pump 1.
11. Let the system run unpressurized for 20 minutes to purge the Pickling Solution.
12. After 20 minutes, close the Pressure Relief Valve finger tight.
13. Check the Feed pressure and Product flow rate are normal.
14. Bypass the Product Water for another 10 minutes then Test the water with the Salinity Sensor.
15. If the water is good, move the Product Valve to the “TANK” position.



**Figure 27: Micron Pre-Filter**

The Clark Pump and the RO Membrane must only operate on 5 Micron filtered Feed Water. Not all “5 Micron” filter elements are the same. Some come with Carbon in them which can let off Carbon “fines” with first use. These Fines will ruin the Clark Pump and Void the Warranty. Use only high quality 5 micron 10” by 2.5” synthetic pleated Sediment Filter Elements. The Filter Status Gauge will tell you the condition of the filter while operating. It is recommended to change the filter before it gets to the red zone. If a filter is going to be cleaned and reused, change Filters when the gauge just starts, or better yet, before it starts to show restriction. Cleaning will be more successful if the particulates are not embedded in hard. Never take off the filter housing, pull out the filter and “look at it” without rinsing out the filter and sump before putting it back together. Dirt gets loose when a filter is lifted out of the sump to look at.

To Open the Filter Sump, first open the Pressure Relief Valve on the Clark Pump to release any residual pressure. Use the supplied Filter Wrench to unscrew the sump. Support the sump as it comes loose and lower down carefully to avoid spilling. Put your hand over the Filter Element and drain the sump. Make sure the Sump O-ring seal hasn't come loose. Clean the Sump then **unwrap** and install a new Filter Element. They go in either way. Check the O-ring, then install the Sump with the Filter and hand tighten only. At startup, Check for a leak. If there is, stop the system and open the Pressure Relief Valve before checking the seal. Tightening it harder with the Filter Wrench is not recommended but may be necessary in some cases.

Filters can be cleaned several times if done carefully with water pressure and a soft brush. They can be cleaned under way by running a line through the filter and tying a stopper knot to hold it on the line. Drag it behind the boat when cruising below 5 knots. If there are any signs of wear on the Filter Pleats, replace the Filter with a high quality pleated synthetic 5-Micron Filter Element. The Brine discharge flow can be used to clean the filters too.

Your membranes **could** require cleaning if you see a 10 psi. **rise** in the feed pressure over the baseline and/or an increase in your TDS levels. The membrane cleaning procedure is a **two-step** process that first uses an alkaline solution to remove any organic fouling **followed by** an acid solution to dissolve and remove scale deposits.

**CAUTION:** The membrane cleaning process utilizes acids and alkaline and proper personal protective equipment should always be worn when handling the cleaning solutions and brine and product water discharge.

**Resistant gloves and eyewear are critical for personal safety.**

- A. The cleaning solutions work better if heated to 95°F, 35°C. Maximum temperature is 107°F, 42°C.
  - B. Have plenty of water in the ship's water tank for flushing.
  - C. Run the system and record the operating pressure and product flow before the cleaning.
  - D. Have clean Prefilter elements installed.
  - E. New membranes are not that expensive. Replacing the membrane may be more economical than cleaning.
1. Follow the Long-Term Storage procedures steps 1 through 7 but use the Alkali Cleaning Chemical instead of the Memstor.
  2. Start both feed pumps and let it recirculate the cleaner unpressurized for at least 1 hour to 3 hours.
  3. Stop the system and let it soak for at least 2 hours to 8 hours
  4. Start both feed pumps and let it recirculate the cleaner for another hour.
  5. While still running, switch the Brine Discharge Service Valve to the Normal Run position.
  6. Drain the Pail and shut down.
  7. Turn the Feed Service Valve to the Normal Run Position.
  8. Perform a "Restart from Long Term Storage Procedure" then record the Feed Pressure and Product flow.
  9. Perform a Freshwater Flush
  10. Rinse out the Service Pail
  11. Repeat the cleaning procedure steps 1 to 8 using the Acid Cleaning Chemical.
  12. If the performance is acceptable the system is ready for use.

After performing both cleanings, compare the 3 performance readings. This will give you an indicator of what type of fouling is affecting the membrane and how well the cleaning has worked. If there was no increase of performance on the Alkaline cleaning but did on the Acid cleaning, just try the Acid cleaning next time. If an Alkaline cleaning is performed, always follow with an Acid cleaning.

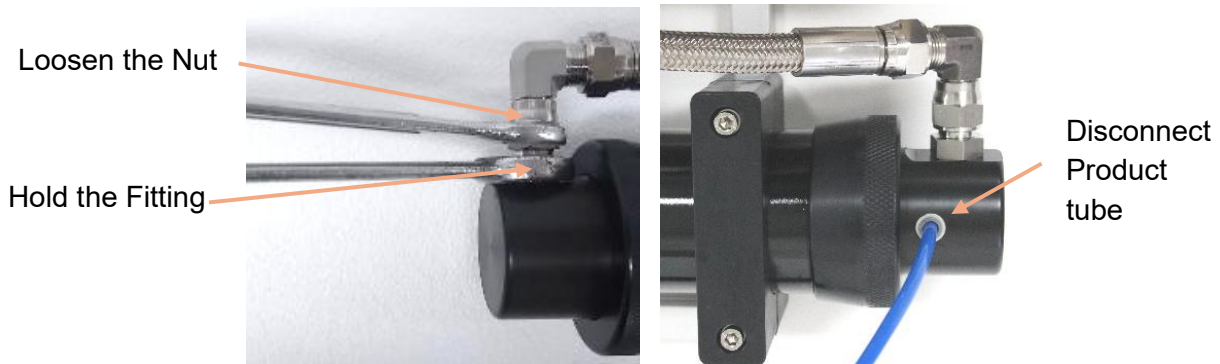
# MEMBRANE REPLACEMENT

The easiest way to replace the membrane is to remove the Pressure Vessel from its mounts for the procedure. It can be done in place but only if there is room enough on the **outlet** end of the Pressure Vessel to pull the membrane out. When the High-Pressure Hoses are disconnected from the End Caps, the hoses are free to be moved out of the way as the special HP fittings in the Enhanced Clark Pump are designed to swivel freely without leaking. The new Membrane element comes sealed in plastic. Don't break the seal until you are ready to insert it. Take a picture of the membrane assembly before starting. Use the packet of silicone grease provided to *lightly* lube the inner edge of the pressure tube before reassembly.

**Warning:** Do not touch the threads on the ends of the Pressure Vessel Tube. It is possible to get fiberglass splinters.

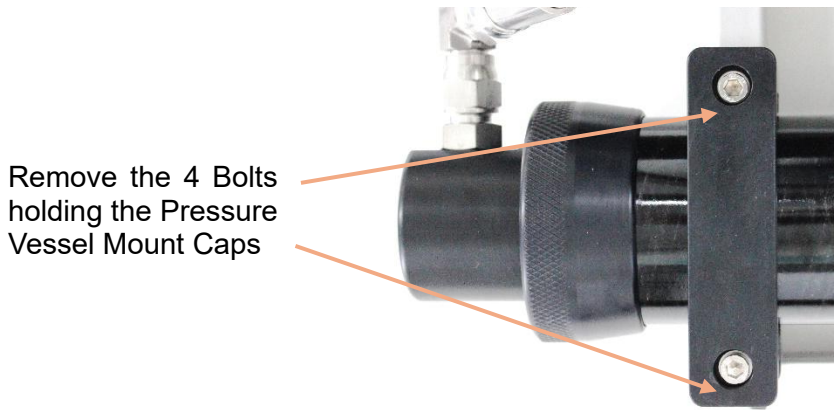


**Figure 28: Pressure Vessel Assembly**



**Figure 29: Disconnecting the HP hoses and Product tube**

Using two wrenches, hold the fitting threaded into the End Cap and loosen the 90° flare fitting connected to the End Cap fitting. Don't let the fitting in the End Cap move. Disconnect the Product Tube. See page (25).

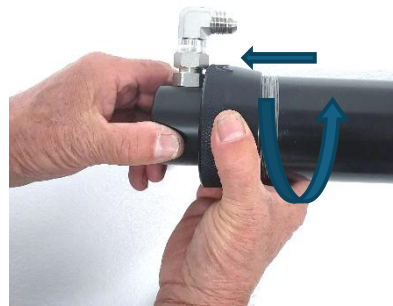


The Pressure Vessel does not have to be removed if there is room off the Outlet end for the Membrane Element to come out.

**Figure 30: Removing the Pressure Vessel**



1. Grasp Metal Ring of Outlet End



2. Unscrew until the ring hits the fitting



3. Twist and pull the End Cap to free seal



4. Continue unscrewing the Ring until free

**Figure 31: Removing the Outlet Endcap**

The End Caps are held on by the metal threaded rings. They are only put on hand tight but can be hard to break loose after the Vessel has been pressurized. If they don't loosen by hand, use the Strap Wrench to loosen. Starting with the Outlet end, unscrew the ring until it meets either the SS HP fitting or the Product Tube fitting. Pull on the End Cap while twisting to start it moving out of the tube and come up against the ring. Keep unthreading the ring while alternately pulling on the end cap until the assembly is free. The Membrane Element is now exposed.

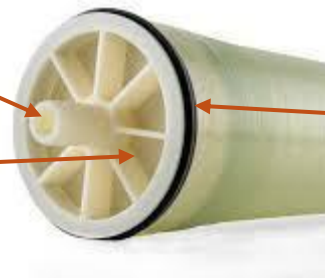


**Figure 32: Pulling the Membrane Element Out**

Using your hand, grasp the white Product Collecting tube in the middle of the membrane to pull it out. If it doesn't want to come out it's because the Brine and Product Collecting Tube seals are holding it. If the membrane element is going to be discarded, use pliers to pull it out. If it still doesn't want to come out or the element is to be reused and not damaged by the pliers remove the Inlet End Cap. The element can now be pushed from its outlet end to remove it from the Inlet end of the Pressure Vessel Tube. Don't mix up the End Caps so they can be reinstalled in the same place.

Product Collecting Tube, it must not have any scratches on the outside surface.

Membrane Material rolled up and covered with a fiberglass wrap.



Membrane Brine lip Seal on inlet end of Membrane

**Figure 33: Parts of the Membrane**

The Membrane Element has no set Feed Flow direction until a Brine Lip Seal is placed on one end. The end with the Brine Seal is placed at the flow inlet of the Pressure Vessel. The Brine Seal directs the Feed Flow through the middle of the Membrane. The Product Water inside the Product Collection Tube is separated from the high-pressure saltwater by an O-ring in the End Cap. The Tube must not be scratched to make this important seal.



1. Lube the Lip of the Seal and bring the Seal end of the Membrane to the Outlet end of the Pressure Vessel Tube at a slight angle



2. Place most of the Seal into the Tube at an angle, some of the lip will not be inside



3. Gently press the exposed lip into the Tube as the membrane is aligned with the tube and the seal slips in



4. Gently push the rest of the way in with a slight twist.

**Figure 34: Inserting the Membrane**

Reinstall the **Inlet** End Cap on the Pressure Vessel Tube if it was removed (see Reinstalling End Cap instructions). The Membrane Element is inserted, Brine Seal first, into the **Outlet** end of the Tube. This seems counter intuitive, but it is the easiest way to install the membrane. *Lightly* lube the Brine Seal, the inner edge of the Vessel Tube, and the OD of the Product Collecting Tube with pure Silicone Grease from the Grease Packet provided. Ideally, wet the inside of the Vessel Tube with fresh water. Place the Membrane in the tube at a slight angle so most of the seal is already inside. Push the last of the seal lip in as the Membrane is aligned with the tube. After the seal slips in, slowly push the Membrane in the rest of the way with a slight twist until it bottoms out. You shouldn't feel any binding. As it bottoms out, you should feel the Product Tube push past the O-ring seal in the Inlet End Cap.



1. Line up the Ring and start threading on the Tube



2. Thread the Ring on until the End Cap Seal contacts the Tube



3. Twist and push the End Cap until the Seal goes in the Tube



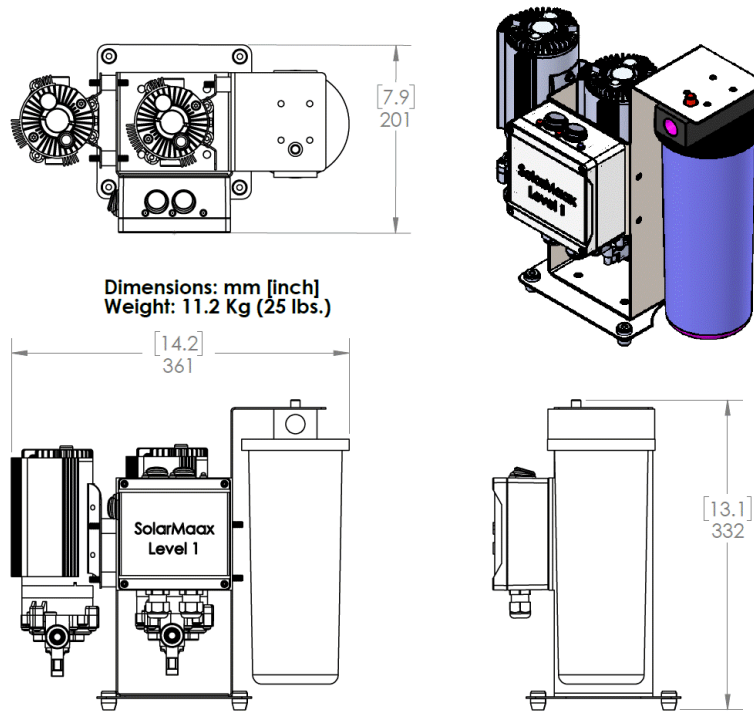
4. Finish threading the Ring on and hand tighten just snug

### Figure 35: Reinstalling the End Cap

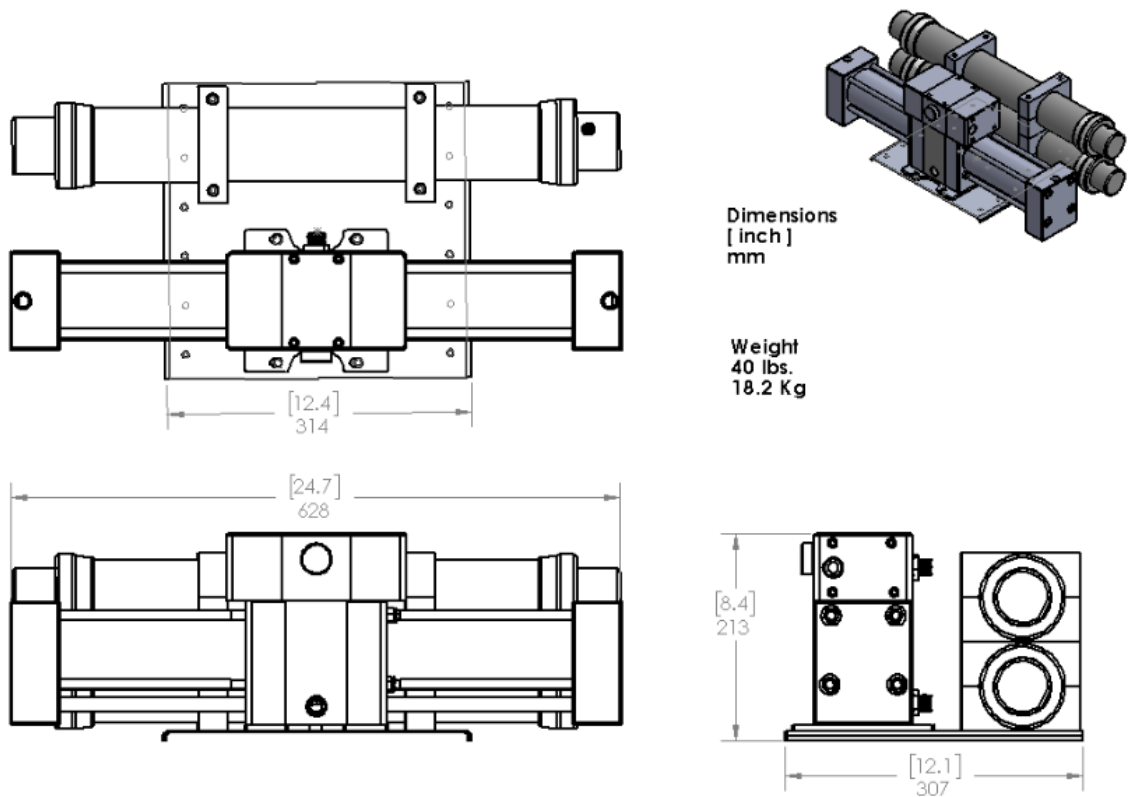
*Lightly* lube the O-ring in the center bore of the end cap and the inner edge of the Vessel Tube with pure silicone grease from the Grease Packet provided. Carefully thread the End Cap Ring onto the Pressure vessel. Do not force the threads. When they engage properly, the ring is easy to turn. Thread on the Ring until End Cap meets the Vessel Tube and resistance is felt. Push and twist the End Cap until the O-ring seal engages with the Vessel Tube and the product tube or hose fitting butt up against the Ring. Continue to thread on the Ring while alternately pushing in the End Cap until it bottoms out and the Ring comes tight against the End cap making it harder to twist. That is as tight as it needs to be. Rotate the End Cap until the HP fitting is at the same orientation as it was before it was removed.

Reinstall the Pressure Vessel in the reverse order it was removed making sure to use two wrenches on the HP fittings so the fitting in the End Cap isn't turned. If the End Cap fitting does get loosened, screw it back in until it becomes snug only. Do not keep tightening and drive it into the plastic. It is sealed by an O-ring and only needs to be snug up against the plastic.

# MODULE DIMENSIONS



**Figure 36: Feed Pump Assembly**



**Figure 37: High Pressure Module, Dual 21" Membrane Dimensions and Weight**

# TROUBLE SHOOTING

| Symptom  | Cause  | Remedy  |
|--|--|---|
| No product Flow  | Pressure Relief Valve open   | Close the pressure relief valve   |
|  | Feed pump not primed   | Open the pressure relief valve until the system primes then close the valve   |
|  | Feed pump won't prime, air getting into the feed line before the Feed Pump | Check all connections and strainer bowl seal in front of the boost pump. Draw water from the service pail to help isolate the leak  |
| Low Product Flow   | Low Voltage  | Voltage range: 12.5 to 14.4 VDC   |
|  | Incomplete prime on the feed pump  | Turn on the freshwater flush to help prime<br><br>Temporarily remove the tube from the prefilter to reduce back pressure.<br><br>Mount feed pump vertically with the pump head down |
|  | Pressure Relief Valve not completely closed                                | Close the Pressure relief valve finger tight  |
|  | External HP leak   | Check HP hose connections and pressure vessel end caps for leaks  |
|  | Internal leaks in the Clark Pump   | Rebuild the Clark pump  |
| Uneven product flow between Clark Pump "Shifts"              | Reversing Valve leaking in one position                                    | Rebuild the Clark Pump  |
|  | Leaking Check Valve  | Rebuild the Clark Pump  |
| Feed Pump cycles ON and OFF every time the Clark pump shifts | Excessive feed pressure spikes   | Set Accumulator pre-charge to 60 psi (4 bar)  |
| Feed Pump cycles ON and OFF                                  | Excessive feed pressure  | Too cold and/or salty feed water.<br>Fouled membrane, clean or replace.   |
|  | Excessive Prefilter inlet/outlet feed pressure differential                | Clogged prefilter, replace  |
| High Products TDS Saltwater leaking into the product         | Bad or missing Membrane Product Tube O-ring seals                          | Check the product tube O-ring and O-ring grooves in the end cap   |
|  | Scratch on the membrane product tube                                       | Remove the scratch with 600 grit sandpaper  |
|  | Poor RO salt rejection   | Clean or replace the membrane   |